

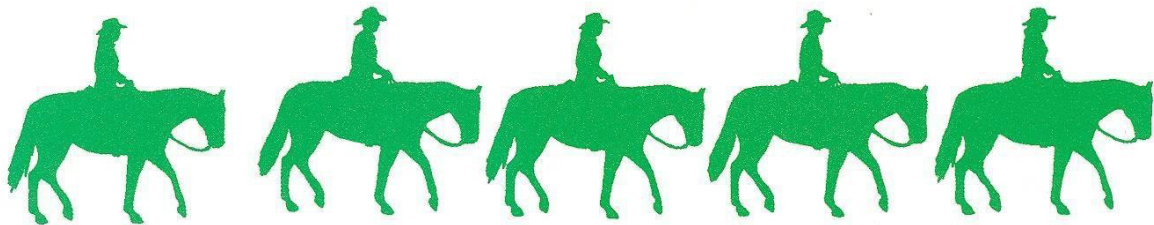

**Texas**  
**4-H**  
**Horse Show**

**Rules and Regulations**

**2026**



# Foreword

This rule book establishes uniform regulations and procedures for qualifying for and participating in the Texas State 4-H Horse Show. These rules govern the State Show, the district shows, and all shows used to qualify contestants for district shows. Only the horse show component of the 4-H program is governed by these rules.

Classes that fit the majority of Texas 4-H members are offered in the State 4-H Horse Show program. Counties are encouraged to develop 4-H horse show activities according to local and county needs and situations. Local and county shows may include other classes where necessary, but such classes may not be used to qualify contestants for district shows.

This rule book is a revision of the original State Horse Show Rule Book, which was first developed in 1966 by Mr. B. F. Yeates, who is now retired and holds the designation of Extension Specialist Emeritus, Texas A&M AgriLife Extension Service. This rule book is revised annually, or as necessary, by the Texas State 4-H Horse Show Committee. When you receive this book, discard copies of any previous editions of the Texas State 4-H Horse Show Rules and Regulations.

**Note: New and significant rules are highlighted in red and/or underlined and are made as per State 4-H Horse Committee recommendations.**

## Use of the Name and Emblem of 4-H

The use of the name and emblem of 4-H is regulated by federal law. This law states that only activities or programs under the supervision of the Texas A&M AgriLife Extension Service may use the name and emblem of 4-H. Therefore, any local, county, district, area, or state 4-H horse show must have the approval of the Texas A&M AgriLife Extension Service through county, district, or state personnel. Shows or events sponsored by other organizations or individuals and shows that do not provide separate classes for 4-H members are not permitted to use the name and emblem of 4-H.

## Acknowledgments

Excerpts and illustrations have been used with permission from the official Handbook of the American Quarter Horse Association, Amarillo, Texas, the Handbook of the American Stock Horse Association, Glen Rose, Texas, and the Equestrian Drill Teams of Texas.

### 4-H Horse Project Team

Jennifer Zoller, Extension Horse Specialist  
Chelsie Huseman, Extension Horse Specialist  
Texas A&M AgriLife Extension Service

# Table of Contents

## Contents

Foreword .....	2
4-H Horse Program Objectives .....	5
General Rules and Regulations .....	6
Eligibility of Participants .....	6
Miscellaneous Show Rules .....	8
Tie-Breaker Guidelines .....	13
High Point Division Awards .....	13
Entries for State Show .....	14
District and State Show Division Classes .....	14
Attire and Equipment.....	17
Hunter and Western Classes: Safety Helmets.....	17
Western Performance Classes: Attire and Equipment.....	17
Judged Classes (Excluding Futurities).....	17
Stock Horse Classes.....	19
Timed Event Classes .....	20
Two-Year-Old Futurity.....	20
Three-Year-Old Futurity .....	21
Hunter Performance Classes: Attire and Equipment .....	21
Division Class Rules.....	23
Halter Division.....	23
Performance Class Rules - <b>Judged Western Division</b> .....	24
Showmanship at Halter .....	24
Western Pleasure.....	27
Western Horsemanship.....	28
Western Trail.....	31
In Hand Trail.....	36
<b>Futurity Division</b> .....	38
Yearling Halter Futurities.....	39
Yearling Futurity .....	39
2-Year-Old Futurity.....	44
3-Year-Old Futurity.....	47
<b>Speed Events Division</b> .....	51
Pole Bending.....	51
Barrel Racing .....	52
Stake Race.....	53
Goat Tying.....	54
<b>Hunter-Flat Division</b> .....	55
Hunter Showmanship.....	55

Hunter Under Saddle .....	55
Hunt Seat Equitation .....	56
Hunt Seat Versatility.....	58
<b>Hunter Over Fences Division</b> .....	59
Hunter Hack .....	59
Working Hunter .....	60
Open Jumping.....	63
Hunt Seat Equitation Over Fences .....	64
<b>Roping Division</b> .....	65
Tie-Down Calf Roping .....	65
Breakaway Roping .....	66
Heading.....	66
Heeling .....	67
Ranch Roping .....	68
<b>Stock Horse Division</b> .....	69
Ranch Sorting .....	69
Working Cow Horse .....	71
Cow Boxing .....	80
Cutting.....	81
Reining .....	82
Freestyle Reining .....	96
Stock Horse Trail.....	97
Stock Horse Pleasure .....	100
Stock Horse Horsemanship .....	103
Stock Horse Showmanship .....	105
<b>Drill Division</b> .....	108
Precision Riding Teams .....	110
Quad Drill .....	116
Texas Equine Liability Law.....	118

# 4-H Horse Program Objectives

The objectives of the Texas 4-H Horse Program include providing means for 4-H members to:

1. Acquire horsemanship and horse-training skills.
2. Gain knowledge concerning science-related subjects, including horse production, management, training, evaluation and use.
3. Prepare for citizenship responsibilities and community service.
4. Develop leadership, initiative, self-reliance, sportsmanship, and other desirable life traits.

The Texas 4-H Horse Program accomplishes these objectives by offering projects and activities in horse management, production, training, and use. The four horse projects are:

- **Horsemanship:** Includes managing, riding, and training older horses with emphasis on learning the skills necessary to cause a horse to perform in a desirable fashion.
- **Training:** Includes managing and training 2- or 3-year-old horses. The project may also involve an older horse that needs further training or focus on advancing a horse to another event.
- **Weanling or Yearling Development:** Includes managing, conditioning, and training a horse until the horse is old enough to be ridden.
- **Mare/Foal:** Includes managing a mare through the complete production cycle, from selecting the sire through weaning the foal.

Available activities vary from county to county. The major statewide activities and programs supporting horse projects are:

- **4-H Horse Show.** Shows are intended to provide a wholesome form of recreation and a forum for demonstrating horsemanship and horse-training skills that lead to recognition and accomplishment. 4-H shows are also held for specific purposes, such as instructional shows, serving as clinics, and open shows, serving as fund-raising activities. Other shows are designed to qualify contestants for competition at the state level. Rules for these shows are found in the publication.
- **4-H Horse Judging.** All 4-H members are encouraged to learn how to evaluate horses. Judging knowledge provides the foundation for training, showing, buying, selling, and producing quality horses. This knowledge establishes the basis for the development of qualified horse show judges. Judging contests provide 4-H'ers with additional opportunities for achievement and recognition. Judging promotes decision-making, justification of thoughts, self-confidence, and public speaking. Rules for the State 4-H Horse Judging Contest are found in the *Texas 4-H Roundup Guide*.
- **4-H Horse Educational Presentation.** Demonstrations, or illustrated talks, challenge 4-H'ers to learn new skills and to share their new knowledge with others. 4-H'ers develop self-confidence and the ability to express themselves while demonstrating skills. *The Texas 4-H Roundup Guide* contains rules for the State Horse Method Demonstration Contest.
- **4-H Horse Record Book.** Records are the basis for many state and national awards. Record books provide an opportunity for 4-H'ers to record accomplishments depicting growth and development. *The 4-H Awards Handbook* contains rules for record book contests.
- **4-H Horse Bowl.** Horse Bowl challenges 4-H'ers to learn about the production, management, training, and use of horses, in addition to other areas of the horse industry. Horse Bowl offers opportunities for recognition and achievement. Rules for the State 4-H Horse Bowl Contest are printed in *The 4-H Horse Bowl Guide* (AS 3-2.020) and the *Texas 4-H Roundup Guide*.

- **Hippology Contest.** Hippology activities encourage 4-H'ers to expand their background in judging, horse bowl, and communication in an all-encompassing contest. *Texas State 4-H Hippology Contest Guidelines.*
- **Equine Ambassadors.** Equine Ambassadors serve their state and their community as leaders and advocates for 4-H, the horse project and the horse industry.  
*<https://texasyouthlivestock.com/equine-ambassador-program/>*
- **Other Projects.** Project areas such as photography, leadership, public speaking, and vet science complement a 4-H member's horse project.

## General Rules and Regulations Eligibility of Participants

1. **Bona fide 4-H Member:** Youth wishing to participate in the State 4-H Horse Show program must be currently enrolled in 4-H and must meet all the requirements established by the club and county programs.
2. **Member Age Requirement:** A contestant may participate in the 4-H year from September 1st of grade three through August 31st following completion of grade twelve, with these age restrictions:
  - a. Minimum age - 8 years old (in addition to being in the 3rd grade)
  - b. Maximum age - 18 years old
  - c. Special education youth who are older than 19 years old and have not graduated from high school may participate in 4-H Youth Development programs as members, with approval by the county Extension agent. Participation is limited to the club or county level. County Extension staff have the option, on a case-by-case basis, to allow Special Education youth older than 19 years old to participate in competitive events at the club or county level.
  - d. **Minimum age for youth showing futurity horses – 12 years old as of September 1<sup>st</sup> of the 4-H year (in addition to being in at least the 6th grade)**
3. **Age Groups:** divisions at the State 4-H Horse Show will include age groups for exhibitors for all classes, EXCEPT Halter, Futurity, Drill/Precision, and Ranch Sorting. 4-H member categories will fall into the following age groups:
  - a. **Junior/Intermediate** (Grades 3, 4, 5, 6, 7, and 8)
  - b. **Senior** (Grades 9, 10, 11, and 12)

\*District 4-H Horse Shows are encouraged to offer age divisions but are not required to do so. Offering age divisions is at the discretion of individual show management.
4. **Awards:** At the State 4-H Horse Show High-Point Saddles will be awarded to Senior Division Winners. Junior Division High-Point Winners will be recognized with a division appropriate award. Class Champions and Reserve Champions in both age groups will receive buckles, while 3rd-10th individuals will receive placing ribbons. Additional awards may be given, as available, and may vary each year. Show management reserves the right to combine age divisions when there were 5 or fewer exhibitors entered in the class the previous year. Classes in which age divisions are combined will receive one champion and one reserve champion buckle, with 3rd-10th individuals receiving placing ribbons.  
\*Awards may vary at District 4-H Horse Shows according to participation and sponsorships. Type of awards offered is at the discretion of individual show

management.

5. **Classes:** At the State 4-H Horse Show, classes with combined Junior and Senior entries of greater than 50 from the previous year will include a Prelims and a Finals. Scores and times will be cumulative (exception: timed roping events are average on 3 head) to determine final placings as described for each individual class in the Texas 4-H Horse Show Rules and Regulations. In classes where finals will be held, a minimum of 10 exhibitors will be called back to the finals. Additional call backs beyond 10 will be at the discretion of the judges and show management. Speed division finals will call back the top 15. When possible, classes at the State 4-H Horse Show will be double judged (Exception: Ranch Roping and Over Fences Classes will be single judged). At the State 4-H horse Show, classes with entries of 5 or fewer contestants or teams from the previous year will be single judged.
  
6. **Texas 4-H Horse Validation – March 1 to May 1:** Validation is required for showing at District or State horse shows, and its purpose is to certify that ownership or lease requirements have been met. The horse **MUST** be owned or leased solely by the 4-H member, his/her parents (biological or stepparents), brother, sister, grandparents, or legal guardian. Horses owned or leased in partnership or jointly with any person other than those previously listed do **NOT** meet ownership requirements.  
Lease horses: An official Texas 4-H Horse Lease Agreement must be signed by the exhibitor, horse owner, and county extension agent. Lease period must include, at minimum, May 1<sup>st</sup> to August 31<sup>st</sup> of the current 4-H Year. The completed Texas 4-H Horse Lease Agreement can be found at <https://texasyouthlivestock.com/horse-validation/> and must be uploaded to Texas Show Pass at the time of validation.  
The horse validation process will be completed electronically, and information regarding validation procedures can be found here: <https://texasyouthlivestock.com/horse-validation/>  
**Horses must be validated or re-validated each year.** All 4-H members who wish to show at their District Show or the State 4-H Horse Show will be **REQUIRED** to validate their horse(s) on the electronic system. Horse validation is completed for **EACH HORSE** and will cover all eligible 4-H youth members in that family profile. Once a horse is validated, validation is paid, and you begin registering for horse shows, the validated horse(s) can be selected by any 4-H member in that family account who will be exhibiting the horse in the show. Validation will be open from **March 1 to May 1**. Any horse validated before or after this date will **NOT** be accepted. An illustrated step-by-step instruction guide for families is available here: <https://texasyouthlivestock.com/horse-validation/>  
Validation cost for each horse is \$10.00 from March 1 – April 15. The only accepted payment method is a credit card through Texas Show Pass. The \$10 cost is only guaranteed if the animal validation is fully submitted and paid for by the deadline. From April 16 – May 1, the validation cost for each horse is \$20.00. The \$20 cost is only guaranteed if the animal validation is fully submitted and paid for by the deadline. There is no limit to the number of horses that can be validated. Any validation that has a status of Draft, Pending Submission, or Issue Reported is not guaranteed the amount charged when it was created and is not considered validated.  
**Note: Photos (front, left side, and right side) are REQUIRED for validation.** The entire horse **MUST** be in the photograph. Photos should be as close as possible, and markings should be clearly visible. **In addition, if the horse is registered with any breed association, a copy of the registration papers will be REQUIRED. If the horse is leased, the official Texas 4-H Horse Lease Agreement will be REQUIRED.** The photos,

registration papers, and lease agreement are to be uploaded in the Texas Show Pass system at the time of validation. The age of the horse is determined on the calendar year, starting on January 1<sup>st</sup> of the year foaled. Horses may be eligible for breed association sponsored awards if they are properly validated as registered horses with correct registration papers uploaded to the online validation system

7. **Horse Ownership Deadline:** For participation in District and State shows and all shows used to qualify contestants for District shows, **the horse MUST be owned or leased and validated as a 4-H project on or before May 1<sup>st</sup> of the current year. All transfer of ownership paperwork for horses must be completed and submitted to Texas Show Pass prior to the validation deadline.** Counties may establish shorter ownership time requirements for local participation, including county qualifying shows. Under no circumstances should a horse be validated for District and State shows, if it was not owned or leased on or before May 1<sup>st</sup>.
8. **Entry Forms for County, District, and State Shows:** See County Extension Agents for County and District Horse Show entry information. All State Show entries must be completed on the online system.

## Miscellaneous Show Rules

The following rules and regulations, set forth by Texas A&M AgriLife Extension Service, via the State 4-H Horse Committee, will apply at all levels of competition prior to and including the State Show and take precedence over any and all other rules.

1. **At State and District Shows, each contestant may enter one or more horses in each Division; however, a horse CANNOT be entered or shown in an individual class more than once. An exhibitor may only enter one horse in each class. In each of the Divisions,** all points will be awarded on a one or more horse/one rider basis.
2. At District and State Shows, **a horse may be exhibited by only one 4-H'er per Class. Separate age groups do NOT count as separate Classes. Example: a horse may be ridden in barrels by one 4-H'er and Stakes by another 4-H'er,** provided that the 4-H'ers are siblings, the ownership requirements are met, and the horse has been properly **validated** as a 4-H project by all 4-H'ers (see validation rules). Exception: Futurity horses may never be ridden by more than one person.
3. The age of the horse shall be computed on the basis of a calendar year starting January 1<sup>st</sup> of the year foaled. It is a weanling during the calendar year in which foaled and a yearling during the first calendar year following its foaling date, regardless of the time of year foaled. On January 1<sup>st</sup>, all horses are considered to be one year older, regardless of actual birth date.
4. A 4-H member may be allowed to change horses between **County, District and State Shows**, provided all horses involved meet **May 1** ownership requirements **and were properly validated.**
5. If for some reason, a 4-H drill team or precision riding member's May 1 validated horse cannot be used, he or she may substitute another May 1 validated and eligible horse. If a May 1 validated and eligible horse is not available, a 4-H'er may use any non-May 1 validate horse, under a drill team or precision riding hardship situation. This hardship substitution situation must be documented in writing by the county agent and verified by an accompanying letter from a veterinarian. This documentation must be sent to the Horse

Specialist's Office, pre-show, or brought to the State Show and given to the Horse Show Office at check-in.

6. Districts shall not offer or hold novice classes during, or affiliated with, the District Shows.
7. **Exhibitors will be judged from the time they enter the arena until their performance is completed.**
8. All classes at the State 4-H Horse Show are open to eligible 4-H youth. Participation at the District 4-H Horse Show is not required but is encouraged; with the exception that a futurity project horse must be shown at the District horse show, district educational clinic, or other equivalent event where the project horse is present (equivalent event determination is under the jurisdiction of each individual district), in order to qualify for a futurity class at State. Participation must be verified by the county extension agent on the State 4-H Horse Show entry form.
9. Stallions **may NOT** be shown at District and State shows. If numbers warrant, counties may provide a class for intact weanlings and/or yearlings to encourage breeding projects.
10. Horses are NOT required to show at halter to be eligible to show in performance events.
11. Halter judging will be based on the horse only.
12. No rerun will be given to any contestant, if handicapped by the failure of his or her own equipment or an accident to the horse or rider.
13. In timed events, at least two watches should be used. The average time of the watches, used by the official timers, will be the official time. An electric timer is preferable and should be used at District and State Shows.
14. Show management decides whether exhibitors run from and/or to an open or closed gate, based on local arena conditions.
15. An exhibitor may NOT be assisted by any other person in the show ring, except in team classes (ranch sorting, team roping, etc.) **No exhibitor may be tied, buckled, or fastened in the saddle in any manner or by any means.** This does not apply to the preference by some timed event exhibitors to use rubber bands around boots, and although their use is discouraged, it is not prohibited.
16. When an exhibitor, exhibitor's parent, or person representing an exhibitor is guilty of poor sportsmanship or rude or unruly behavior, the show management, judge, or class superintendent may suspend such exhibitor's rights to participate in the class, future classes, and/or shows for such a period as deemed appropriate.
17. A contestant **may be disqualified** from a class, at the judge's discretion, for receiving excessive verbal instructions from outside the ring while said exhibitor is performing.
18. A show official (show manager, judge, or class superintendent) may **disqualify** any horse or exhibitor from the competition for bad, unruly, and/or dangerous behavior.
19. Unsoundness may be penalized at the discretion of the judge. This decision is NOT subject

to protest.

20. The use of any stimulants or depressants is prohibited. Any surgical procedure or drug that could affect a horse's performance or alter its natural conformation is prohibited. **Only NSAIDs prescribed by a licensed veterinarian are allowed** (Ex: Phenylbutazone is legal.). Drug testing may be conducted at show management's discretion.
21. Any time a horse's mouth is tied or fastened in a performance class, the horse **shall be disqualified**. Any open, raw sores or bleeding body parts that come in contact with a hackamore, bit, spur, or other related equipment may be penalized at the judge's discretion.
22. The Texas State 4-H Horse Program is committed to the humane treatment of horses and cattle. Inhumane or abusive treatment **may result in disqualification**, at the discretion of the show management, members of the horse show management team, and/or judges.
23. The judge's decision shall be final and is NOT subject to protest. Video review is not available. Participant recorded video will not be considered.
24. A disqualified horse shall NOT be placed in a class (although it will be counted as an entry) in which the disqualification or "no score" occurred. The horse shall NOT receive points for disqualification in a class (exception: runoffs involving ties).
25. Scores are NOT official until verified with judges' cards and posted.
26. Exhibitors and exhibitors' parents are responsible for keeping track of working orders and for being in line or in the makeup arena when their run or heat time arrives. **Exhibitors who miss their heat or run will forfeit their run in that class, unless they notify the class superintendent of an unpreventable emergency before their time to work has passed and show management approves the request.**
27. Questions regarding the conduct of the show will be referred immediately to the show managers. The show managers will confer with the show officials, judge, or class superintendent. If necessary, the show manager will give an on-the-spot decision that shall be accepted as final.
28. An appeals committee will be designated by the show management before the show begins. This committee will receive and act upon protests arising out of any class. A protest must be filed in writing, accompanied by a **\$200 cash fee**, during or immediately upon conclusion of the event. Protests may only be submitted by the exhibitor, the affected exhibitor's parent, or legal guardian or by a county extension agent. If the protest is upheld by the appeals committee, the deposit shall be refunded to the protester. If the protest is overruled, the deposit shall be forfeited to the horse show fund.
29. Class information (patterns, order, ground rules, etc.) will be made available through digital means a minimum of 1 hour before the class starting time. It is the exhibitor's responsibility to be aware that this information is available.
30. Exhibitors who stall their horses without paying or who stall their horses in unassigned stalls or tie horses out overnight are subject to **disqualification** from the Texas State 4-H Horse Show. Only one horse is allowed per stall at any time. At the State 4-H Horse Show, stalls and tack stalls may be added at the show, if available. Stalls are available only for

horses that are entered in the show, and show management approved turnback horses, judges horses, horses belonging to show management and clinician horses.

31. Alcoholic beverages are prohibited on the show grounds.
32. Dogs are NOT allowed on the show grounds. Exception: service animals specifically trained to aid a person with a disability are allowed. Violators may be subject to dismissal from the show. Exotic animals are not permitted on show grounds.
33. Motorized vehicles are allowed at the State 4-H Horse Show with the following restrictions: Drivers must be 18 years of age or older, vehicles are not allowed in arena buildings or breezeways, vehicle types are restricted to golf carts and utility task vehicles (UTV). Motorcycles, scooters, bicycles, skate-boards, skates, etc. are prohibited. **Exhibitors may be disqualified from the State 4-H Horse Show, if they or their family members are found in violation. It is the responsibility of all exhibitors, family members, and friends to make sure that such equipment is used appropriately.**
34. If an exhibitor dismounts for any reason other than a class requirement, they will receive a disqualification.
35. The fall of a horse or rider being judged shall be cause for **disqualification** in all classes. A horse is considered to have fallen when he or she is on their side and all four feet are extended in the same direction. A rider is considered to have fallen when he or she is not astride.
36. At District and State Shows, all exhibitors should refrain from allowing their horse(s) to be ridden or schooled on the ground (including longeing and showmanship preparation) by anyone other than the exhibitor. Many 4-H'ers have family members who will want to help hold, groom, saddle, and bridle horses in preparation for classes. This is encouraged, because family involvement is an important part of the 4-H Horse Program.
37. All exhibitors and other 4-H members attending District or State Horse Shows should wear appropriate 4-H attire at all times, including during social activities held in conjunction with or as a part of the horse show. Those not conforming may be asked to change attire or leave the event.
38. Failure to display the correct exhibitor number will result in disqualification.

## Show Point Systems & Points Within Divisions

**System A.** State Show will use System A. See Figure 1. District shows may choose between system A and B but must declare which system will be used prior to the start of the show, and **should place first through tenth in all classes; however, they have option of placing through fifteenth in all classes.** County shows may use systems A, B, or C.

Points awarded for placing in class															
Contestants in class	1st	2nd	3rd	4th	5th	6th	7th	8th	9th	10th	11th	12th	13th	14th	15th
1-3	1														
4-7	2	1													
8-11	3	2	1												
12-15	4	3	2	1											
16-19	5	4	3	2	1										
20-24	6	5	4	3	2	1									
25-29	7	6	5	4	3	2	1								
30-34	8	7	6	5	4	3	2	1							
35-39	9	8	7	6	5	4	3	2	1						
40-44	10	9	8	7	6	5	4	3	2	1					
45-49	11	10	9	8	7	6	5	4	3	2	1				
50-54	12	11	10	9	8	7	6	5	4	3	2	1			
55-59	13	12	11	10	9	8	7	6	5	4	3	2	1		
60-64	14	13	12	11	10	9	8	7	6	5	4	3	2	1	
65 & over	15	14	13	12	11	10	9	8	7	6	5	4	3	2	1

**Figure 1. System A, used for determining points at district shows and the Texas State 4-H Horse Show.**

**System B.** Each of the first 10 horses in a class will be given a point for each horse placing below it, plus one point. Points are calculated through tenth place.

**Example 1:** In a class of 24 horses, the first place contestant receives 24 points; the second place gets 23 points; and so on down through tenth place.

**Example 2:** In a class of four horses, first place gets 4 points, second gets 3 points, third gets 2 points, and fourth gets 1 point.

**System C.** For county shows. Each of the first 10 horses in a class will be given a point for each horse placing below it, plus one point for a maximum of 10 points.

**Example:** In a class of 15, first place received 10 points, second receives 9 points, third receives 8 points, and so on through tenth place, which receives 1 point.

## Tie-Breaker Guidelines

**Tie Breakers (Individual Class Placings):** In the case of a tie in timed or scored classes, ties will be broken by the fastest time, highest score, or rail work in the finals. In all other classes (or should a tie still exist, or no finals are held), a tiebreaker judge shall be designated prior to the beginning of the class. If a tie still exists, a tiebreaker maneuver will be used, maneuver must be designated prior to the start of the class. If a tie still exists, a runoff will be held for the top three places. In timed events, with the exception of roping events, the contestant declared the winner must run the pattern in no more than 2 seconds more than his/her original time or the runoff must be held again. Material awards for all other places will be decided by the flip of a coin; points will be split. Drill Division: first tiebreaker is degree of difficulty, second tie breaker is horsemanship, third tiebreaker is spacing.

**Tiebreakers (High Points):** Break ties as follows: 1) placing in greater number of classes within the division; 2) greater number of horses placed over in all classes within the division. If a tie still exists, contestants will be named Co-Champion and duplicate Champion awards will be provided at show management expense. No Reserve Champion will be named.

**Tie Breaker (Futurity Classes):** In the case of a tie in futurity classes, ties shall be broken first on the basis of the horse that placed the highest most often. If a tie still exists, it will be broken using the placing of the tie-breaker judge.

In yearling longe line, ties are broken first on the highest score in the longeing portion before considering conformation. If a tie still exists, tie-breaker judges' total score shall be used.

## High Point Division Awards

**Champion Judged Horseman.** Most total points earned in the following classes: Showmanship at Halter, Western Pleasure, Western Horsemanship, and Trail. To be eligible for all Champion and Reserve Champion Judged Horseman Awards, all points counted will be for one 4-H'er with **one or more horses**.

**Champion Timed Horseman.** Most total points earned in 3 of the 4 following classes: Pole Bending, Barrel Racing, Stake Race, and Goat Tying (**one or more horses /one rider**). To be eligible for all Champion and Reserve Champion Timed Horseman Awards, a contestant must have placed (through tenth place) in at least two timed events.

**Champion Hunter-Flat Horseman.** Most total points earned with **one or more horses/one rider** in the following classes: Hunter Showmanship, Hunter under Saddle, Hunt Seat Equitation, and Hunt Seat Versatility.

**Futurity Divisions.** Since there is only one class in each of the five Futurity Divisions, there are no High Point or Reserve High Point Awards in these divisions. The Futurity Horseman Award is dependent upon sponsor support and if available will be awarded to the highest placing 3 year old who has been shown as a yearling, 2 year old and 3 year old futurity project at the State 4-H Horse Show. There is no accumulation of points from year to year, the award is based solely on the ranking during the 3 year old year.

**Halter Division.** Since the first and second place horse from the mare and gelding classes come back to show for selection of grand and reserve champion, there are no other high-point awards in the halter division and halter points do not count toward high point in any of the other divisions at either District or State Shows.

**Champion Hunter over Fences Horseman.** Most total points earned with one or more horses/ one rider in the following classes: Hunter Hack, Working Hunter, Equitation over Fences, and Open Jumping.

**Champion Roper.** Based on points in four roping classes: Tie-Down Calf Roping, Breakaway Roping, Heading and Heeling. Must place (through tenth place) in more than one event. If no contestant places in more than one class, Champion Roper will be awarded to the person with the highest number of points in one class. Champion Roper is figured on a one or more horses/one rider basis.

**Champion Stock Horseman.** Based on points in the following classes: Cutting, Reining, Ranch Sorting, Working Cow Horse, Stock Horse Trail, Stock Horse Pleasure, Stock Horse Horsemanship, and Stock Horse Showmanship. Must place (through tenth place) in more than one event. If no contestant places in more than one class, Champion Stock Horseman will be awarded to the person with the highest number of points in one class. Champion Stock Horseman is figured on a one or more horses/one rider basis.

---

---

## 4-H Horse Shows

---

---

**County Qualifications:** All 4-H members meeting horse project requirements are eligible to compete. **All horses must have been validated by May 1<sup>st</sup>.**

**District Qualifications:** District shows may accept any number of county entries, or county quotas may be sent by the District Extension Agent based on facilities and show schedule. Districts are encouraged to allow as many exhibitors as possible to compete in District Shows.

District horse show entry procedures are provided to County Extension offices by the District Extension office.

**State Qualifications:** All 4-H members meeting horse project requirements are eligible to compete. **All horses must have been validated by May 1<sup>st</sup>.**

### Entries for State Show

1. All contestants coming to District Shows should be prepared to tell the show management whether or not they intend to participate in the State Show.
2. **Contestants must register for the State 4-H Horse Show using the online registration system.**
3. **County and District approval of State Show entries is REQUIRED within 4HOnline. Absolute entry deadline is July 1. No late entries will be accepted.**
4. A 4-H'er who is already entered in the State Show by the **July 1** deadline may make a class change or may add a class at the State Show for a \$50 fee. These class changes or class additions should be handled in person at the show in the horse show office. No changes will be accepted by phone or email during the period from July 1 until arrival at the State Show.
5. Tack stalls **may** be available at the State 4-H Horse Show on a **limited** basis. This decision will be made by Show Management.

### District and State Show Division Classes

**District & State 4-H Horse Shows** – All of the following divisions and classes are offered at the State 4-H Horse Show. Districts may offer a District Horse Show. A futurity project horse must be shown at the District horse show, district educational clinic, or other equivalent event where the project horse is present, in order to qualify for a futurity class at State.

#### **Halter Division**

**(1 or more horses per 4-H'er, but only 1 horse per class)**

Geldings 4 and Under

Geldings 5 and Over

Grand & Reserve Champion Gelding

Mares 4 and Under

Mares 5 and Over

Grand & Reserve Champion Mare

**Judged Western Division**

**(1 or more horses per 4-H'er, but only 1 horse per class)**

Showmanship at Halter  
Western Pleasure  
Western Horsemanship  
Western Trail  
In Hand Trail (does not count for High Point)

**Hunter-Flat Division**

**(1 or more horses per 4-H'er, but only 1 horse per class)**

Hunter Showmanship  
Hunter Under Saddle  
Hunt Seat Equitation  
Hunt Seat Versatility

**Speed Events Division**

**(1 or more horses per 4-H'er, but only 1 horse per class)**

Barrel Racing  
Pole Bending  
Stake Race  
Goat Tying

**Yearling Halter Gelding Futurity Division**

**(1 horse per 4-H'er)**

Yearling Halter Geldings

**Yearling Halter Filly Futurity Division**

**(1 horse per 4-H'er)**

Yearling Halter Fillies

**Yearling Futurity Division**

**(1 horse per 4-H'er)**

Yearling Longe Line  
Yearling Showmanship  
Yearling In-hand Trail

**2-Year-Old Futurity Division**

**(1 horse per 4-H'er)**

2-Year-Old Futurity Pleasure Pattern  
2-Year- Old Futurity Versatility  
2-Year-Old Futurity Western Pleasure (**finalists only**)

**3-Year-Old Futurity Division**

**(1 horse per 4-H'er)**

3-Year-Old Futurity Pleasure  
3-Year- Old Futurity Trail  
3-Year-Old Futurity Reining

**Roping Division**

**(1 or more horses per 4-H'er, but only 1 horse per class)**

Tie-Down Calf Roping

Breakaway Roping  
Team Roping Heading  
Team Roping Heeling  
Ranch Roping

**Hunter Over Fences Division**

**(1 or more horses per 4-H'er, but only 1 horse per class)**

Working Hunter  
Equitation Over Fences  
Hunter Hack  
Open Jumping

**Stock Horse Division**

**(1 or more horses per 4-H'er, but only 1 horse per class)**

Ranch Sorting  
Reining  
Working Cow Horse  
Cow Boxing - Open to any horses not being shown in Working Cow Horse (does not count for High Point)  
Cutting  
Ranch Cutting (does not count for High Point)  
Stock Horse Trail - Open to any horses not being shown in regular Western Trail.  
Stock Horse Pleasure - Open to any horses not being shown in regular Western Pleasure.  
Stock Horse Horsemanship - Open to any horses not being shown in regular Western Horsemanship.  
Stock Horse Showmanship- Open to any horses not being shown in regular Western Showmanship.

**Drill/Precision Riding Division**

Mounted Drill Team  
Quad Drill

Precision Riding Team Approval of all **State Show entries** from Counties and Districts are due within the online entry system **by July 1**. No late entries will be accepted. The classes have no qualification procedures. Any 4-H member who meets the eligibility requirements and is certified by a County Extension Agent may enter the show classes. There is no limit to the number of classes a 4-H'er may enter or the number of horses he or she may show in the State Show. **However, refer to Miscellaneous Show Rules 1, 2, and 3.**

---

---

# Attire and Equipment

---

---

## Hunter and Western Classes: Safety Helmets

During all over-fence classes and schooling over-fence events, it is **MANDATORY** that all riders wear properly fitted headgear with a fastened chin harness. During timed-event classes, it is strongly recommended that all riders wear properly fitted headgear with a fastened chin harness. In all other judged and timed classes, the use of protective headgear is acceptable, recommended, and the optional choice of the exhibitor. ASTM/SEI helmets are recommended. It is the responsibility of the rider and the parent, guardian, or trainer of the 4-H member to ensure that the headgear worn complies with appropriate safety standards for protective headgear intended for equestrians' use, and that the headgear is properly fitted and in good condition.

The Texas A&M AgriLife Extension Service, Texas State 4-H Horse Program, and the District and State Horse Show Management Teams are not responsible for ensuring that the headgear worn complies with safety standards and make no representation or warranty, expressed or implied, about any protective headgear, and cautions riders that death or serious injury may result despite wearing such headgear, because all equestrian sports involve inherent dangerous risks, and no helmet can protect against all possible injuries.

## Western Performance Classes: Attire and Equipment

The use of protective headgear is the optional choice of exhibitors in any and all western classes, including judged, timed, roping, stock horse, and futurity classes.

### Judged Classes (Excluding Futurities)

Halter, western pleasure, stock horse pleasure, western horsemanship, stock horse horsemanship, western showmanship, In Hand Trail, stock horse showmanship, working cow horse, cow boxing, cutting, reining, trail, **Ranch Roping** and stock horse trail:

**Attire.** Riders shall wear western hat, long-sleeve shirts, and western boots. **Western boots shall include typical cowboy boots and lace-up ropers. All other footwear is prohibited. Any boot other than a leather sole boot is strongly discouraged.** The use of spurs and chaps shall be optional, except that they are prohibited in Showmanship. Clothing should be neat and clean.

**Equipment.** Horses shall be shown in a stock saddle that fits the rider. Silver equipment will not count over good, clean, working equipment. Horses may be ridden with a curb, spade, or half-breed bit. **Split reins must be used and held in one hand with no more than one finger between the reins.** When using a romal, no fingers between the reins are allowed. In Cutting, split reins are required, and in Ranch Cutting a romal is legal. During Reining, the use of the free hand while holding the romal to alter the tension or length of the reins from the bridle to the reining hand is considered to be the use of two hands, and a score of 0 will be applied, with the exception of any place a horse is allowed to be completely stopped during a pattern. In all other classes, including the reined portion of working cow horse, the free hand may be used to adjust the rider's length of rein. Riders, 4-H age 12 years and older, are eligible to show Junior horses (aged 5 & Under as of January 1<sup>st</sup> of the current year) in a **snaffle bit** (excludes Cutting). Bosal

is not permitted except for 2 Year Old Futurity horses. Equipment must follow the bit specifications outlined under 2 Year Old Futurity. Riders intending to show in a snaffle bit at the State 4-H Horse Show must indicate that intention on their entry form.

All curb bits must be free of mechanical devices and should be considered a standard western bit. A description of a legal, standard western curb bit includes:

1. 8 1/2" (215 mm) maximum length shank to be measured as indicated in the diagram below. Shanks may be fixed or loose.
2. Concerning mouthpieces, bars must be round, oval or egg shaped, smooth and unwrapped metal of 5/16" to 3/4" (8 mm to 20 mm) in diameter, measured 1" (25 mm) from the cheek. They may be inlaid, but must be smooth or latex wrapped. Nothing may protrude below the mouthpiece (bar), such as extensions or prongs, including upward prongs on solid mouthpieces. The mouthpiece may be two or three pieces. A three- piece, connecting ring of 1 1/4" (32 mm) or less in diameter, or a connecting flat bar of 3/8" to 3/4" (10mm to 20 mm) measured top to bottom with a maximum length of 2" (50 mm), which lies flat in the horse's mouth, is acceptable.
3. The port must be no higher than 3 1/2" (90 mm) maximum, with rollers and covers acceptable. Broken mouthpieces, half breeds, and spades are standard. Slip or gag bits and donut and flat polo mouthpieces are not acceptable.

**ACCEPTABLE CHAIN CHIN STRAPS**



**WESTERN BITS**

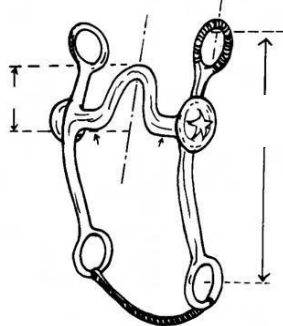

LEGAL BIT

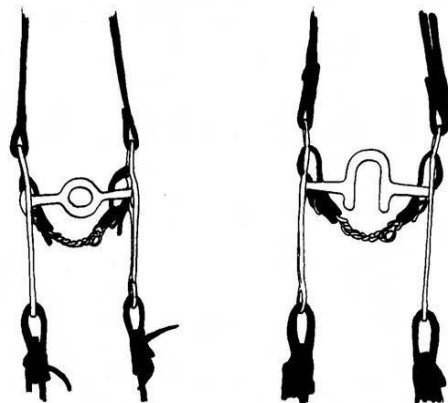

DONUT BIT

ILLEGAL BITS

PRONG BIT

Curb bits must have a curb chain or strap, and it must be at least ½ inch in width and must lie flat against the horse's chin. No wire curbs are permitted, regardless of the amount of padding or tape. Absolutely no iron will be permitted under the jaws. Mechanical hackamores are prohibited. Bosals or nosebands are not permitted with a bit. Gag bits, tie downs, martingales, and draw reins are prohibited.

***Protective boots and leg wraps are not allowed in halter, showmanship at halter, stock horse showmanship, western pleasure, or trail.***

## Stock Horse Classes

***All stock horse division classes: no banded or braided manes, or hoof black will be allowed.***

**Attire.** Riders shall wear western hat, long-sleeve shirts, and western boots. Attire should be traditional and conservative in appearance and should not display extraordinary decorations. Judges may, at their discretion, fault exhibitors who are in violation of the intent of this rule. **No chaps, or chinks of any kind will be allowed in Stock Horse Showmanship or Stock Horse Horsemanship classes.** A conservative scarf around the neck is allowed but should not detract from the overall conservative appearance of the exhibitor. **Equipment.** Tack should be traditional and conservative in appearance and should not display extraordinary silver or other decorations other than normal buckles. Judges may fault exhibitors who are in violation of the intent of this rule. No banded or braided manes, or hoof black will be allowed. Rules concerning legal reins, bits and other tack are same as other western classes.

For Cow Boxing class ONLY – horses can be shown in a snaffle bit with two hands on the reins or can be shown in a curb bit with only one hand on the reins. (This applies to both the reining portion and cow work portion of the class). Split reins must be used and held in one hand with no more than one finger between the reins (with curb bit). When using a romal, no fingers between the reins are allowed.

## Timed Event Classes

Pole bending, barrel racing, stake race, goat tying, calf roping, breakaway roping, team roping, and ranch sorting:

**Attire.** Exactly like judged classes. ***Long-sleeve shirts and western boots are required. Boots other than leather soled boots are discouraged.*** Western hat is optional, and, if worn, should be affixed in a manner to keep it from coming off the rider. Caps are prohibited.

**Equipment.** Western-type equipment must be used. The use of a mechanical hackamore, gag bit, or other type of bridle is the contestant's choice. However, the officials or judge may require the removal or alteration of equipment considered severe, dangerous, or inhumane. Contestants may use tie downs.

## Two-Year-Old Futurity

**Attire.** Same as other judged classes.

**Equipment.** Horses must be shown two-handed in either a smooth snaffle or a bosal. Any bit having shanks, and therefore curb action of any type, is prohibited. References to snaffle bits in futurity classes mean the conventional O-ring, egg-butt, or D-ring with a ring no larger than 4" (100 mm). The inside circumference of the ring must be free of rein, curb, headstall, or

**mouthpiece** attachments which would provide leverage. The mouthpiece should be round, oval or egg- shaped, smooth and unwrapped metal. It may be inlaid, but smooth or latex wrapped. The bars must be a minimum of 5/16" (8 mm) in diameter, measured one inch (25 mm) in from the cheek with a gradual decrease to center of the snaffle. The mouthpiece may be two or three pieces. A three-piece, connecting ring of 1 1/4" (32 mm) or less in diameter, or a connecting flat bar of 3/8" to 3/4"(10 mm to 20 mm) measured top to bottom, with a maximum length of 2" (50 mm), which lies flat in the horse's mouth, is acceptable. Optional curb strap attached below the reins on a snaffle bit is acceptable.

Split-reins are mandatory with snaffle bits. Two methods of holding the reins are acceptable. One rein may be held in each hand, or both reins may be held with both hands. If one rein is held in each hand, the tail of each rein must lay across the horse's neck. If a hackamore (bosal) is used, it must be a flexible, braided rawhide, leather or rope bosal, the core of which may be either rawhide or flexible cable. Absolutely no rigid material will be permitted under the jaws, regardless of how padded or covered. Horse hair bosals are prohibited. This rule does not refer to a so-called mechanical hackamore.

There should be approximately 1 1/2 inches between the bosal and nose. A continuous hackamore rein is permitted. Mechanical hackamores, gag bits, twisted-wire snaffles, martingales, tie downs, and draw reins are prohibited.

**Protective boots and leg wraps will only be allowed in the 2-Year-Old Futurity Versatility class.**

## Three-Year-Old Futurity

**Attire.** Same as other judged classes.

**Equipment.** Horses must be shown two-handed in a smooth snaffle as previously described for 2-year-old futurity horses. Hackamores (bosals) are NOT permitted.

Gag bits, twisted-wire snaffles, martingales, tie downs, and draw reins are prohibited.

**Protective boots and leg wraps will only be allowed in the 3-Year-Old Futurity Trail and Reining classes.**

## Hunter Performance Classes: Attire and Equipment

### Judged Classes

Hunter showmanship, hunter under saddle, hunt seat equitation, hunt seat versatility, hunter hack, working hunter, open jumping, hunt seat equitation over fences:

**Attire.** See the section titled Hunter and Western Classes Safety Helmets. Clothing must be clean and neat. The rider must wear a coat, boots, breeches, and hunting cap or helmet. The coat may be any tweed or melton (conservative, washable jackets in season) acceptable for hunting, such as navy, dark green, gray, black, or brown. Maroon and red are NOT acceptable. Breeches or jodhpur pants should be traditional shades of buff, brown, khaki, canary, light gray, or rust. Boots may be black or brown. A black, dark blue, or brown hard-hat is **required**. Spurs of the unrowelled type, gloves, crops, and bats are optional. Gloves are preferred in the equitation class and should be heavy wash leather or brown leather.

Judges or show management may authorize adjustments to attire because of weather. See

the section on Hunter Showmanship for specific attire and equipment.

**Acceptable English Bits  
For All Ages**

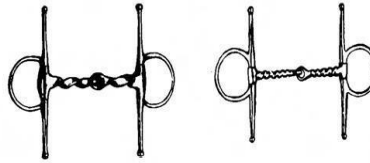

Slow Twist

Corkscrew

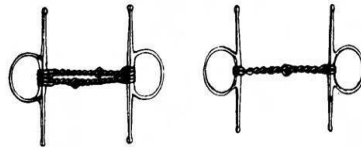

Double Twisted Wire

Single Twisted Wire

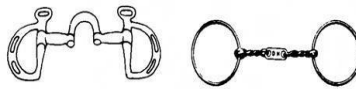

Correction Bit

Snaffle Bit with  
Connecting Flat Bar

**Unacceptable English Bits**

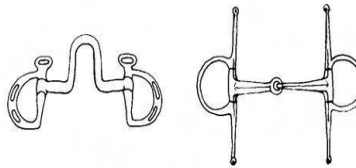

Excessive Port

Triangular Mouth

**Equipment.** Traditional hunting or forward-seat-type saddles shall be used and should be black and/or brown leather. A knee insert on the skirt is optional. Saddle pads should fit size and shape, except when necessary to accommodate exhibitor numbers on both sides, for which a square pad or suitable attachment may be used. Saddle pads should be white or natural color with no ornamentation. In all English classes, an English snaffle (no shank), kimberwick, pelham and/or full bridle (with two reins), all with cavesson nosebands and plain leather brow bands, **MUST** be used.

In reference to mouthpieces, nothing may protrude below the mouthpiece (bar). Solid and broken mouthpieces must be between 5/16" to 3/4" (8 mm to 20 mm) in diameter, measured 1" (25 mm) from the cheek and may have a port no higher than 1 1/2" (40 mm). They may be inlaid, synthetic wrapped, including rubber or plastic or incased, but must be smooth. On broken mouthpieces only, connecting rings of 1 1/4" (32 mm) or less in diameter or connecting flat bar

of 3/8" to 3/4" (10 mm to 20 mm) measured top to bottom with a maximum length of 2" (50 mm), which lie flat in the horse's mouth, are acceptable. Snaffle bit rings may be no larger than 4" (100 mm) in diameter. Any bit having a fixed rein requires use of a curb chain. Smooth round, oval or egg-shaped, slow twist, corkscrew, single twisted wire, double twisted wire mouthpieces, and straight bar or solid mouthpieces are allowed.

Neck straps are acceptable but must be attached to the saddle. In the open jumping class only, mechanical hackamores and flash nosebands may be used.

Bits of any style (pelham, snaffle, kimberwick) featuring mouthpieces with cathedrals, donuts, prongs, edges, or rough, sharp material shall be cause for **elimination**. Square stock, metal wrapped or polo bits shall be cause for **elimination**. If a curb bit is used, the chain must be at least 1/2" (15 mm) in width and lie flat against the jaw of the horse.

Breastplates are optional. Draw reins, hackamores, boots, or bandages are all prohibited (exception: boots or leg wraps are legal in open jumping). Martingales are NOT allowed in flat classes or hunter hack.

## Division Class Rules

### Halter Division

A halter class is defined as a class where the horse is judged based upon its conformation.

The purpose of the class is to select individuals in the order of their resemblance to the breed ideal and that are the most positive combination of balance, structural correctness, breed and sex characteristics, and muscling.

The ideal halter horse has eye appeal that is the result of a harmonious blending of an attractive head, refined throat latch, well-proportioned, trim neck, long, sloping shoulder, deep heart girth, short back, strong loin and coupling, long hip and croup, and well-defined and muscular stifle, gaskin, forearm and chest. These characteristics should be coupled with straight and structurally correct legs and feet that are free of blemishes. The horse should be a balanced athlete that is muscled uniformly throughout.

Conformation is defined as the physical appearance due to the arrangement of muscle, bone, and other body tissues.

One of the most important criteria in selecting a horse is conformation, or its physical appearance. While it could be assumed that most horses with several years seasoning and past performance have acceptable conformation, the goal in selection should always be to find the best conformed horse possible.

Rating conformation depends upon objective evaluation of four traits: balance, structural correctness, breed and sex characteristics, and degree of muscling. Of the four, balance is the most important and refers to the structural and aesthetic blending of body parts. Balance is influenced almost entirely by skeletal structure.

### Equipment

**Lip chains: Mares and geldings may not be shown with any item through the mouth, including, but not limited to, lip chains.**

### Judging Procedure

Horses will walk to the judge one at a time. As the horse approaches, the judge will step to the right (left of the horse) to enable the horse to trot straight to a cone placed at 50 feet (15 meters) away. It is at the judge's discretion whether horses will trot straight past this cone or

turn left and continue trotting. After trotting, horses will be lined up head to tail for individual inspection by the judge. The judge shall inspect each horse from both sides, front, and rear. The judge should line the horses to be placed in a head-to-tail order according to preference.

When judging of all classes in a halter division has been completed, all first- and second-place class winners of that sex division shall return to the ring, with first-place class winners in one line and second-place horses from each class in another line.

The judge must select a Grand Champion and Reserve Champion in each sex division.

The judge(s) shall select the Grand Champion mare or gelding from the first-place class winners in the respective sex division. If the first-place horse does not return for any reason, the second-place horse will move up to the first-place line and be considered for Grand and Reserve. The third-place horse cannot move up to second place in the class.

The second-place horse in the class from which the Grand Champion had been selected will be judged with the first-place class winners for the title of Reserve Champion mare or gelding in the respective sex division.

## Performance Class Rules - Judged Western Division

### Showmanship at Halter

The showmanship class is judged on an exhibitor's ability to execute practical and basic halter class maneuvers from the ground. The class should always be judged with this in mind, giving credit to the exhibitor who can correctly perform each maneuver of the total pattern or run. Judges should refrain from conducting the class routine in any manner that attempts to trick, confuse, or mislead exhibitors. In showmanship at halter, conformation of the horse is not judged.

**Attire.** Exhibitors should be neat, clean, and well-groomed. Clothing shall be as stated in the section on judged classes. Chaps and spurs are NOT permitted in showmanship.

**Equipment.** Use a clean halter that is adjusted to fit the horse. The halter should fit well on the horse's head, to maximize response to subtle halter cues. Silver halters shall not count over a nice, clean, well-fitted halter. Lead straps are often attached to a chain and snap. The lead strap may be snapped below the jaw in the center ring of the halter, or the chain can be run under the horse's chin and snapped to the upper or lower halter ring on the right side of the horse's head.

### Horse Fitting and Grooming

1. The horse should be clean and well-groomed. Manner of fitting for mane and tail may vary according to recognized practices for a particular breed of horse.
2. A well-groomed horse that is clean, properly trimmed, and conditioned does have a justified advantage in showmanship at halter. Underweight or thin horses may be penalized.

### Method of Showing

1. Walk, trot, turn, stop, back, and pose the horse as shown in the posted pattern or by the judge's instructions.
2. The horse is always led from the left side. The exhibitor's right hand is held closest to the halter, with the distance being highly dependent upon the mannerisms of the horse, the size of both the horse and the exhibitor, and breed standards. The excess amount of lead is folded or loosely coiled in the left hand and held about waist high. Never wrap the excess lead around the hand or make a coil so small that a sudden jerk could cause the lead to wrap around the hand. At both the walk and the trot, the exhibitor's shoulder should be about even with the horse's throatlatch. In this position, the horse is beside the exhibitor, allowing the judge a clear view of the horse's travel. Movement at both gaits should be brisk and sharp, as opposed to slow and dull. Speed of travel is somewhat related to straightness of travel, and the slower a horse moves, the greater chance for deviation from a straight line of movement.
3. When leading to or from a judge or ringmaster, stops and turns are very important. The exhibitor should always allow plenty of space between the horse and the judge. Stops should be executed squarely and without hesitation, as the stop is an important maneuver preceding a correct turn or reverse of direction.
4. Turns of more than 90 degrees should always be executed to the right. Pushing the horse away, rather than pulling the horse around, will allow more distance between the horse's and the exhibitor's feet. In addition, turning to the right allows the horse to use the right hind foot as a pivot point. The horse can then cross the left front foot over the right front to execute a very uniform and smooth turn. This results in the horse remaining in essentially the same tracks after the turn is completed and provides the judge a good view as the horse is walked or trotted away.
5. Immediately following a turn or reverse of direction, the exhibitor should look back to make sure the horse is lined up with the judge. Class routines may require walking or trotting back into the lineup of horses. The exhibitor should lead all the way through the line, stop, reverse, and then lead into the line to set up. If asked to change positions in the line, back the horse out of the line, and approach the new position from behind.
6. Pose or set up the horse with its feet set according to its type or breed. Stock horse breeds stand square. Move the horse's feet by pushing or pulling on the lead strap as necessary with the right hand. Touching the horse's body with a hand or foot to change the horse's position is penalized.
7. Once set up, the horse should be presented in such a way as to not distract the judge's attention from the horse. The exhibitor stands on the opposite side of the horse when the judge is toward the front and on the same side as the judge when the judge is toward the rear of the horse. This method of presentation is preferred by most judges for youth exhibitors.
8. For safety reasons, at no time should an exhibitor stop and stand directly in front of the horse.
9. The primary objective is to show the horse. Exhibitors should stand where they can see the judge and the judge can see them, but without obstructing the judge's view of the horse. The basic position of the exhibitor should allow constant observation of the horse's position

and also permit observation of the judge.

10. Staring at the judge keeps an exhibitor from continually observing the horse and keeping the horse set properly. Exhibitors should maintain eye contact with the horse. It is acceptable to glance at the judge from time to time, but an exhibitor should NOT do this continuously.

Exhibitors should keep their proper position in line and allow reasonable space (at least 5 feet) between horses on either side. Keep horses from making contact with a competitor or encroaching on space rightfully belonging to another exhibitor. Scoring

1. Exhibitors will be scored from 0 to infinity with 70 denoting an average performance. Patterns will be divided into 6 to 10 maneuvers, as specified by the judge, and each maneuver will be scored from +3 to -3 with  $\frac{1}{2}$  point increments acceptable that will be added or subtracted from 70. Maneuver scores should be determined independent of penalties, and should reflect equal consideration of both performance of the exhibitor's pattern and the form and effectiveness of the exhibitor and presentation of horse to result in the following scores: +3 excellent, +2 Very Good, +1 Good, 0 Average or Correct, -1 Poor, -2 Very Poor, -3 Extremely Poor. Exhibitors overall form and effectiveness should also be scored from 0 to 5 with 0 to 2 being Average, 3 Good, 4 Very Good, 5 Excellent.
2. Penalties
  - a. 3 Points
    - i. Break of gait at walk or trot for up to two strides
    - ii. Over or under turning up to  $\frac{1}{8}$  of a turn
    - iii. Ticking or hitting cone
    - iv. Sliding a pivot foot
    - v. Lifting a pivot foot during a pivot or set-up and replacing it in the same place
  - b. 5 Points
    - i. Not performing the gait or not stopping within 10 feet of the designated area
    - ii. Break of gait at walk or trot for more than 2 strides
    - iii. Splitting the cone (cone between the horse and handler)
    - iv. Horse stepping out of or moving the hind end significantly during a pivot or turn
    - v. Horse resting a foot or hipshot in a set-up
    - vi. Horse stepping out of set-up after presentation
    - vii. Over/under turning  $\frac{1}{8}$  to  $\frac{1}{4}$  turn
  - c. 10 Points
    - i. Exhibitor is not in the required position during inspection
    - ii. Exhibitor touching the horse or kicking or pointing their feet at the horse's feet during the set-up
    - iii. Standing directly in front of the horse
    - iv. Loss of lead shank, holding chain or two hands on shank
    - v. Horse stepping out of or moving the hind end significantly during a pivot or turn more than one time
    - vi. Severe disobedience including rearing or pawing; horse continually circling exhibitor
  - d. Disqualifications
    - i. Loss of control of horse that endangers exhibitor, other horses or judge
    - ii. Horse becomes separated from exhibitor

- iii. Failure to display correct number
  - iv. Willful abuse
  - v. Excessive schooling or training; use of artificial aids
  - vi. Illegal equipment
- e. Off pattern, including: knocking over or wrong side of cone or marker; never performing designated gait; over or under turning more than ¼ turn; must place below exhibitors who complete pattern correctly

### Class Routine

1. Exhibitors may enter the arena single-file, moving around the arena counter-clockwise before lining up at the judge's instruction. Once in line, each exhibitor will perform individually.
2. At many shows, exhibitors will be asked to enter the arena individually and work a pattern designed by the judge.
3. Regardless of the manner used, judges should draw patterns clearly and make instructions that are easily understood by exhibitors.
4. Where patterns are posted, such instructions should be available for the exhibitor to review prior to the start of this class (at least 1 hour before, if possible).

### Western Pleasure

This class recognizes a horse for functional correctness, quality of movement, attitude, and manners.

1. Horses are shown at a walk, jog, and lope on a reasonably loose rein without undue restraint. Horses must work both ways of the ring, at all three gaits, to demonstrate their ability with different leads and transitions. Riders may be asked to extend the jog at the judge's discretion. An extended jog is a definite two-beat lengthening of stride and covering more ground. Cadence and balance with smoothness is more essential than speed. Horses may be required to reverse at the walk or jog and to go from any gait to another gait at the discretion of the judge. For safety of the exhibitors, a reverse at a lope or extended jog shall not be called.
2. Horses should back easily and stand quietly. The judge may ask that only finalists be backed.
3. Horses are to be reversed to the center of the arena.
4. Large numbers in this class may require qualification heats to accommodate all horses.

Arena size will dictate heat size. After each heat, all horses should be brought to the center with the finalists identified.

5. Any portion of a class or heat may be placed on the rail for extra work by the judge at any time.

6. At no time shall a fault-out system that results in exhibitors being eliminated individually be used. A positive approach should be used, the winners or finalists being announced and the remainder of the class being dismissed from the arena as a group. Individual horses should not be pulled off the rail while the class is being judged.
7. Entries shall be penalized for being on wrong leads, but not necessarily disqualified. Excessive speed and breaking gait are to be penalized. Horses with a low head carriage and/or head carriage behind the vertical and/or a sullen, lethargic, emaciated, drawn, or tired look will be penalized. Horses which lack forward motion at any gait may be penalized.
8. The class will be judged on the performance and condition of the horse at the discretion of the judge.

## Western Horsemanship

This class recognizes the exhibitor's ability to ride a horse functionally and correctly using various aids to cause the horse to perform required basic maneuvers.

### General

1. Riders will be judged on basic position in the saddle, which includes the position and use of hands, seat, feet, and legs, as well as the ability to control and show the horse.
2. Scores on individual works will be based on rider's skills and execution of the pattern.

### Position

1. Arms and hands. Arms and hands should be held in an easy, relaxed manner. Upper arms are held in a straight line with the body, with the arm holding the reins bent at the elbow. Only one hand is used for reining, and hands shall not be changed on the reins. The hand is to be around the reins with one finger permitted between split reins. Reins are to be carried immediately above and slightly in front of the saddle horn. Reins should be held so that light contact is maintained with the horse's mouth.
2. Basic position. The rider should sit in a comfortable, balanced, relaxed, and flexible manner. The lower leg should hang straight down from the knee or forward to the stirrups with a slight bend in the knee, depending on the type of saddle. In either position, stirrups should be just long enough for heels to be lower than toes. The feet should be placed in the stirrups with the boot heel touching the stirrup or slightly less deep. Riding with the weight on the toes will be penalized. The toes should be turned only slightly out, with the ankles flexed in a comfortable position. The lower legs and feet should be kept close to the horse's body, but not in contact except when applying aids.

### Position in Motion

The rider shall sit the jog and not post. The rider should be close to the saddle at a lope. Exaggerated shifting of the rider's weight is not desirable and will be penalized in judging.

### Class Routine

1. The judge will ask each rider to work individually. Individual works will be a combination of maneuvers that the judge feels are necessary to determine the horsemanship ability of the rider. The pattern will include maneuvers from the following list, or any maneuvers that the judge feels are appropriate to test the horseman's ability:
  - a. straight walk, jog, and lope, and circles in both directions.
  - b. stop.
  - c. back straight, in an "L", and in a circle.
  - d. 360-degree turn or spin.
  - e. pivot, both ways.
  - f. turns of 90, 180 or 270 degrees.
  - g. rollbacks
  - h. lope circles of varying size and speed.
  - i. pick up leads from standstill, walk, or jog.
  - j. simple lead changes on a straight away or in a circle.
  - k. side pass.
  - l. counter canter.
  - m. two track.
  - n. Drop and pick up stirrups
2. The pattern should be posted at least 1 hour before the class begins, if at all possible.
3. The judge will use these individual work scores to determine the top riders who will be asked to work individually or on the rail. Selected riders (or all riders if the class is small) will be required to work on the rail to determine final placing. Rail work is optional for the State Show and may or may not be held.
4. Rail work will include walk, jog, and lope in one or both directions of the ring at the discretion of the judge.

## Scoring

1. Exhibitors will be scored from 0 to infinity with 70 denoting an average performance. Patterns will be divided into 6 to 10 maneuvers, as specified by the judge, and each maneuver will be scored from +3 to -3 with ½ point increments acceptable that will be added or subtracted from 70. Maneuver scores should be determined independent of penalties, and should reflect equal consideration of both performance of the exhibitor's pattern and the horsemanship form and effectiveness of the exhibitor to result in the following scores: +3 excellent, +2 Very Good, +1 Good, 0 Average or Correct, -1 Poor, -2 Very Poor, -3 Extremely Poor. Exhibitors overall horsemanship form and effectiveness should also be scored from 0 to 5 with 0 to 2 being Average, 3 Good, 4 Very Good, 5 Excellent. Exhibitors may also be judged on the rail, and their pattern score and/or ranking may be adjusted as appropriate.
2. Penalties:
  - a. 3 Points
    - i. Break of gait at walk or jog/trot up to 2 strides
    - ii. Over/under turn from 1/8 to ¼ turn
    - iii. Tick or hit of cone
    - iv. Obviously looking down to check leads
  - b. 5 Points

- i. Not performing the specific gait or not stopping when called for in the pattern within 10 feet of the designated area
    - ii. Incorrect lead or break of gait (except when correcting an incorrect lead) at the lope
    - iii. Break of gait at walk, jog or trot for more than two strides
    - iv. Loss of stirrup
    - v. Head carried too low and/or clearly behind the vertical while the horse is in motion, showing the appearance of intimidation
  - c. 10 Points
    - i. Loss of rein
    - ii. Use of either hand to instill fear or praise while on pattern or during rail work
    - iii. Holding saddle with either hand
    - iv. Cueing with the end of the romal
    - v. Blatant disobedience including kicking, pawing, bucking and rearing
    - vi. Spurring in front of cinch
  - d. Disqualifications
    - i. Failure to display correct number
    - ii. Abuse of horse or schooling
    - iii. Fall by horse or rider
    - iv. Illegal equipment or illegal use of hands on reins
    - v. Use of prohibited equipment
  - e. Off pattern, including: knocking over cone or wrong side of cone or marker; never performing designated gait or lead; over or under turning more than ¼ turn; must place below exhibitors who complete pattern correctly.

## Western Trail

This class will be judged on the performance of the horse over obstacles, with emphasis on manners, response to the rider, and quality of movement. Credit will be given to horses negotiating the obstacles with style and some degree of speed, providing correctness is not sacrificed. Horses should receive credit for showing attentiveness to the obstacles and the capability of picking their own way through the course when obstacles warrant it and willingly responding to the rider's cues on more difficult obstacles.

1. Horses shall be penalized for any unnecessary delay while approaching or negotiating the obstacles. Horses with artificial appearance over obstacles should be penalized.
2. Horses must not be required to work on the rail. The course must be designed, however, to require each horse to show the three gaits (walk, jog, lope) somewhere between obstacles as a part of its work, and quality of movement and cadence should be considered as part of the maneuver score. While on the line of travel between obstacles, the horse shall be balanced, carrying his head and neck in a relaxed, natural position, with the poll level with or slightly above the withers. The head should not be carried behind the vertical, giving the appearance of intimidation, or be excessively nosed out, giving a resistant appearance. Gait between obstacles shall be at the discretion of the judge.
3. The course to be used must be posted at least one hour before scheduled starting time

of the class.

4. Scoring will be on the basis of 0-infinity, with 70 denoting an average performance. Each obstacle will receive an obstacle score that should be added or subtracted from 70 and is subject to a penalty that should be subtracted. Each obstacle will be scored on the following basis, ranging from plus 1½ to minus 1½: -1½ extremely poor, -1 very poor, -½ poor, 0 correct, +½ good, +1 very good, +1½ excellent. Obstacle scores are to be determined and assessed independently of penalty points. Penalties should be assessed per occurrence as follows:

The following deductions will result:

0 – SCORE

1. Use of more than one finger between reins
2. Use of two hands or changing hands on reins; only one hand may be used on the reins, except that it is permissible to change hands to work an obstacle.
3. Illegal use of equipment
4. Equipment failure that delays completion of pattern
5. Excessively or repeatedly touching the horse on the neck to lower the head
6. Fall to the ground by horse or rider

Off Pattern – must place below exhibitors who complete the pattern correctly

1. Performing the obstacles incorrectly or other than in specified order
2. No attempt to perform an obstacle
3. Failure to enter, exit or work obstacle from correct side or direction, including overturns of more than 1/4 turn
4. Failure to work an obstacle in any manner other than how it's described by the course
5. Riding outside designated boundary marker of the arena or course area
6. Third refusal
7. Failure to demonstrate correct lead or gait, if designated
8. Failure to follow the correct line of travel within or between obstacles
9. Faults that occur on the line of travel between obstacles, which will not be cause for disqualification, but will be faulted according to severity:
  - a. head carried too low (tip of ear below the withers *consistently*)

- b. over-flexing or straining neck in head carriage so the nose is carried behind the vertical *consistently*.

One-half (1/2) point

1. Each tick of log, pole, cone, or obstacle

One (1) point

1. Each hit, bite or stepping on a log, pole, cone, plant or obstacle
2. Incorrect gait at walk or jog for two strides or less
3. Both front or hind feet in a single-strided slot or space
4. Skipping over or failing to step into required space
5. Split pole in lope over
6. Failure to meet the correct strides on jog over and lope over log obstacles, if specified

Three (3) points

1. Break of gait at walk or jog for more than 2 strides
2. Out of lead or break of gait at lope (except when correcting an incorrect lead)
3. Knocking down an elevated pole, cone, barrel, plant obstacle, or severely disturbing an obstacle
4. Stepping outside the confines of, falling, or jumping off or out of an obstacle with one foot
5. Missing or evading a pole that is a part of a series of an obstacle with one foot

Five (5) points

1. Dropping slicker or object required to be carried on course
2. First or second cumulative refusal, balk, or attempting to evade an obstacle by shying or backing more than 2 strides away
3. Second refusal
4. Letting go of gate or dropping rope gate
5. Use of either hand to instill fear or praise
6. Stepping outside the confines of, falling, or jumping off or out of an obstacle with more than one foot
7. Blatant disobedience (kicking out, bucking, rearing, striking)
8. Holding saddle with either hand
9. Missing or evading a pole that is a part of a series of an obstacle with more

than one foot

5. Management, when setting courses, should keep in mind that the idea is not to trap a horse, or eliminate it by making an obstacle too difficult. All courses and obstacles are to be constructed with safety in mind, so as to eliminate any accidents. When the distances and spaces are measured between all obstacles, the inside base to inside base measurement of each obstacle considering the normal path of the horse should be the measuring point. Enough space must be provided for a horse to jog (at least 30 feet) and lope (at least 50 feet) for the judges to evaluate these gaits.
6. If disrupted, the course shall be reset after each horse has worked. In the case that a combination of obstacles is used, the course cannot be reset until the contestant finishes the entire course, regardless of where any disruption occurs.
7. At least six obstacles must be used, three of which must be from the mandatory list of obstacles, and at least three others selected from the list of optional obstacles.
8. Mandatory obstacles:
  - A. Opening, passing through, and closing gate. (Losing control of gate is to be penalized.) Use a gate which will not endanger horse or rider. If the gate has a metal, plastic, or wooden support bar under the opening, contestants must work the gate moving forward through it.
  - B. Ride over at least four logs or poles. These can be in a straight line, curved, zig-zag or raised. The space between the logs is to be measured, and the path the horse is to take should be the measuring point. All elevated elements must be placed in a cup, notched block, or otherwise secured so they cannot roll. The height should be measured from the ground to the top of the element. Spacing for walk overs, jog overs, and lope overs should be as follows or increments thereof.
    - 1) The spacing for walk overs shall be 20" to 24" (40 cm to 60 cm) and may be elevated to 12" (30 cm). Elevated walkovers should be set at least 22" (55 cm) apart. The spacing for jog overs shall be 3' to 3'6" (90 cm-105 cm) and may be elevated to 8" (20 cm).
    - 2) The spacing for lope overs shall be 6' to 7' or increments thereof, and may be elevated to 8".
    - 3) It is highly recommended that patterns for District horse shows contain both jog overs and lope overs, in order to better prepare trail class exhibitors for the State Show.
  - C. Backing obstacle. Backing obstacles to be spaced a minimum of 28" (70 cm). If elevated, 30" (75 cm) spacing is required. Entrants cannot be asked to back over a stationary object such as a wooden pole or metal bar.
    - 1) Back through and around at least three markers.
    - 2) Back through L, V, U, straight, or similar-shaped course. May be elevated no more than 24" (60 cm).

9. Optional obstacles, but not limited to:

- A. Water hazard (ditch or small pond). No metal or slick bottom-boxes will be used.
- B. Serpentine obstacles at walk or jog. Spacing to be minimum of 6' (1.8 meters) for jog.
- C. Carry object from one part of arena to another. (Only objects which reasonably might be carried on a trail ride may be used.)
- D. Ride over wooden bridge. (Suggested minimum width shall be 36" (90 cm) wide and at least six feet long). Bridge should be sturdy, safe, and negotiated at a walk only.
- E. Put on and remove slicker.
- F. Remove and replace materials from mailbox.
- G. Side pass (may be elevated to 12" (30 cm) maximum).
- H. An obstacle consisting of four logs or rails, each 5' to 7' (1.5 to 2.1 meters) long, laid in a square. Each contestant will enter the square by riding over log or rail as designated. When all four feet are inside the square, rider should execute a turn, as indicated, and depart.
- I. Any other safe and negotiable obstacle which could reasonably be expected to be encountered on a trail ride and meets the approval of the judge may be used.
- J. A combination of two or more of any obstacle is acceptable.

10. Unacceptable obstacles:

- A. Tires
- B. Animals/Hides
- C. PVC pipe
- D. Dismounting
- E. Jumps
- F. Rocking or moving bridges
- G. Water box with floating or moving parts
- H. Flames, dry ice, fire extinguisher, etc.
- I. Logs or poles elevated in a manner that permits such to roll
- J. Ground ties

11. The judge must walk the course prior to the start of the class and has the right and duty to alter the course in any manner. The judge may remove or change any obstacle they deem unsafe or non-negotiable. If at any time a trail obstacle is deemed to be unsafe by the judge, it shall be repaired or removed from the course. If it cannot be repaired and horses have completed the course, the score for that obstacle shall be deducted from all previous works for that class.

**Back Through and Around Three Markers**

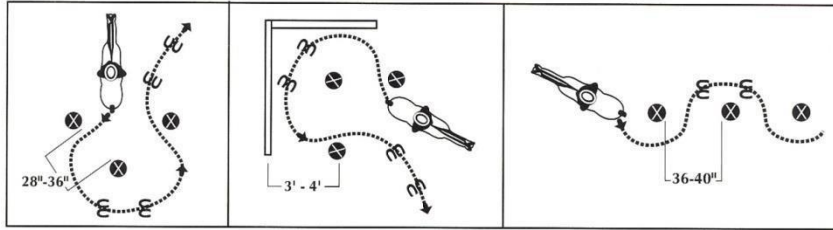

**Back Through and Around Three Markers**

**Trot Overs, Lope Overs**

**Walk Overs**

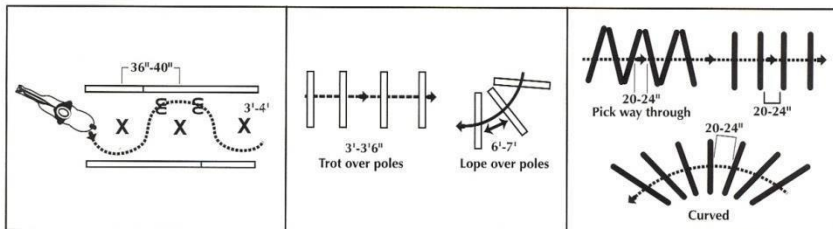

**Variations of Sidepass**

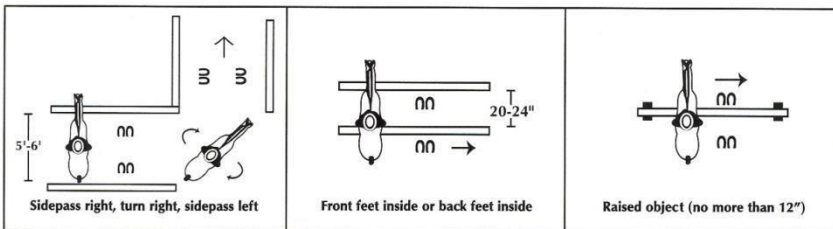

**Variations of Sidepass**

**Variations of L Back Through**

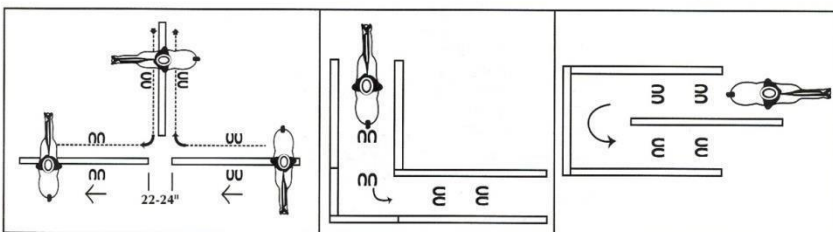

**In Hand Trail**

The class will be judged on the performance of the horse over obstacles, with emphasis on manners and way of going. Credit will be given to horses negotiating the obstacles with style, without hesitancy and willingly responding to the handler's cues. Horses shall be penalized for any unnecessary delay while approaching the obstacles. Judges should consider the overall appearance of the horse, conditioning and grooming, and the equipment (dirty, ill-fitting or ragged equipment should be penalized) in their overall scores. Also to be considered is the correctness of the horse while being led. Drifting to the side, leading or stopping crooked, failure to maintain a pivot foot in a turn, leading or turning sluggishly should be considered and evaluated in the horse's maneuver scores and reflected in his overall score. Handlers should be discouraged from excessive verbal cues and excessive stiff or unnatural movements around the horse or when leading.

**Class Routine**

Horse is to be led through the course with the exhibitor on the horse's left side. The exhibitor should be positioned between the eye and the midpoint of the neck. The exhibitor may change sides to negotiate obstacles.

### Scoring

1. Scoring will be on the basis of 0-infinity, with 70 denoting an average performance. Each obstacle will receive an obstacle score that should be added or subtracted from 70 and is subject to a penalty that should be subtracted. Each obstacle will be scored on the following basis, ranging from plus 1½ to minus 1½: -1½ extremely poor, -1 very poor, -½ poor, 0 correct, +½ good, +1 very good, +1½ excellent. Obstacle scores are to be determined and assessed independently of penalty points. Penalties should be assessed per occurrence as follows:
2. Penalties:
  - a. ½ Point
    - i. Each tick of log, pole, cone, plant or obstacle
  - b. 1 Point
    - i. Each hit, bite or stepping on a log, pole, cone, plant or any component of the obstacle
    - ii. Incorrect or break of gait at walk or jog for two strides or less
    - iii. Both front or hind feet in a single-strided slot or space.
    - iv. Skipping over or failing to step into required space
  - c. 3 Points
    - i. Incorrect or break of gait at walk or jog for more than 2 strides
    - ii. Knocking down an elevated pole, cone, barrel, plant or obstacle, or severely disturbing an obstacle unless caused by the tail
    - iii. Horse stepping outside the confines of, falling or jumping off or out of an obstacle with one foot once the foot has entered an obstacle; including missing one element of an obstacle on a line of travel with one foot. Handler may travel/stand inside or outside of the obstacle, as needed.
  - d. 5 Points
    - i. Dropping slicker or object required to be carried on course
    - ii. First or second cumulative refusal, balk, or evading an obstacle by shying or backing
    - iii. Letting go of gate or dropping rope gate
    - iv. Use of either hand to instill fear or praise (slight touching or tapping with one hand to cue horse in a sidepass maneuver only is acceptable)
    - v. Horse stepping outside the confines of, falling or jumping off or out of an obstacle with more than one foot once the foot has entered an obstacle; including missing one element of an obstacle on a line of travel with more than one foot. Handler may travel/stand inside or outside of the obstacle, as needed.
    - vi. Blatant disobedience (including biting, kicking out, bucking, rearing, striking or continuously circling exhibitor)
  - e. Disqualification
    - i. Loss of control of horse that endangers exhibitor, other horses or judge
    - ii. Fall of horse or handler
    - iii. Failure to display correct number
    - iv. Willful abuse
    - v. Excessive schooling or training; use of artificial aids
    - vi. Illegal equipment

Off Pattern, including: performing the obstacles other than in specified order, no attempt to perform an obstacle, third cumulative refusal, wrong side of cone or marker, never performing designated gait; over or under turning more than ¼ turn, must place below exhibitors who complete pattern correctly

## Futurity Division Classes

**All 4-H'ers validating and showing futurity project horses MUST be at least in the 6th grade and 12 years old or older as of September 1 of the current 4-H year. To be eligible for State Show Futurity classes, a 4-H'er MUST show in the Futurity classes at the District Show or an equivalent event approved by the District.**

The Texas 4-H Horse Program offers five futurities to 4-H horse exhibitors as follows:

1. Yearling Halter Geldings: stock-type.\*
2. Yearling Halter Fillies: stock-type.\*
3. Yearling Longe Line: for fillies or geldings of any breed.\*
4. 2-Year-Old Futurity: for 2-year-old geldings or fillies (any breed of horse) to be shown in a snaffle bit or bosal.
5. 3-Year-Old Futurity: for 3-year-old geldings or fillies (any breed of horse) to be shown in a snaffle bit.

\* **Note:** A yearling may be shown in halter only, halter and longe line, or longe line only.

**All futurity projects MUST be officially validated by May 1.**

**Philosophy:** Older horses are desirable for young and/or beginning 4-H members to help them acquire knowledge and skill prior to attempting a training project. In showing an older horse effectively, a rider acquires some training skills, and these foundational skills help prepare a 4-H'er for handling a training project. The futurity classes provide a challenge and recognition for older experienced members. All 4-H'ers nominating futurity projects must be in the 6th grade and 12 years old or older as of September 1 of the current 4-H year.

### General Rules for Futurities

1. Horses must be solely owned or leased by 4-H members, their parents (biological or step), brother, sister, grandparents, or legal guardian. Horses owned in partnership or jointly with any person other than those previously listed do NOT meet ownership requirements.
2. Horses must be in 4-H member's possession and under his or her management and care by **May 1**.
3. Members may validate more than one horse for each or all of the futurities; however, a 4-H member may show only one horse in each futurity.
4. All yearling halter, yearling longe line, 2-year-old futurity and 3-year-old futurity projects **MUST** be validated from **March 1 to May 1 via the 4HOnline system**. There will be an option in the system to indicate that the horse is a futurity horse. No late entries will be accepted.
5. Futurity horses are to be ridden two-handed in either a smooth snaffle or a bosal (2-year-

old futurity) or a smooth snaffle (3-year-old futurity). Refer to specific futurity project attire and equipment rules in Western Performance Class: Attire and Equipment section. Members with properly **validated** horses enter their project(s) in the State 4-H Horse Show by registering for and paying show entry fee(s) **via 4HOnline**.

6. At the State 4-H Horse Show, all futurity projects must be checked-in, which includes having the horse aged by the teeth by the State Show veterinarian. Exhibitors of 2 and 3 year old futurity projects should also bring their bridles to check-in for approval by show management. See the State 4-H Horse Show schedule for check-in date and time.
7. Futurity horses may be shown prior to the District and State 4-H Horse Show; however, after the horse becomes a futurity project on **May 1**, it can be ridden or shown **ONLY** by the 4-H member.
8. Advice and counsel on fitting, developing, and/or training techniques may come from outside sources. With yearlings, individuals other than the 4-H'er may assist with grooming, but **ONLY** the 4-H'er can show the horse at any and all horse shows after **May 1**. **With yearlings validated for longe line, the actual process of longeing the horse on a longe line constitutes training. Therefore, after May 1, the yearling longe line horse can be worked on a longe line ONLY by the 4-H'er.** Family members are not to ride or show yearling, 2-year-old, or 3-year-old futurity horses at any time after **May 1**.

## Yearling Halter Futurities

### Equipment

**Lip chains: Mares and geldings may not be shown with any chain through the mouth including but not limited to lip chains.**

### Judging Procedure

Horses will walk to the judge one at a time. As the horse approaches, the judge will step to the right (left of the horse) to enable the horse to trot straight to a cone placed at 50 feet (15 meters) away. It is at judge's discretion whether horses will trot straight past this cone or turn left and continue trotting. After trotting, horses will be lined up head to tail for individual inspection by the judge. The judge shall inspect each horse from both sides, front, and rear.

The judge should line the horses to be placed in a head-to-tail order according to preference.

## Yearling Futurity

General Rules for Yearling Futurity:

1. The Yearling Futurity is a preparatory division for yearlings that may eventually be shown as 2-year-old futurity or 3-year-old futurity horses. This division consists of three classes: Yearling Longe Line, Yearling Showmanship and Yearling In-hand trail.
2. Attire may be either English or Western.

Western: The 4-H'er shall wear a Western hat and western boots. Long-sleeved shirts are required. Clothing should be neat and clean. Gloves are optional.

English: The 4-H'er shall wear a coat, boots, breeches, and hunting cap appropriate to

Hunter classes. Gloves are optional.

Whether in English or Western attire, the use of protective headgear is the optional choice of the exhibitor.

3. Yearling futurity prospects must be designated as a futurity project in 4HOnline and entered through the same process as 2- and 3-year-olds in the futurity horse program.
4. The Yearling futurity is held separately from the yearling halter futurity competition. Separate awards are given.
5. The horses are to be shown in a *flat* nylon, leather, or rope halter.
6. The snap on the longe line and/or lead rope may include a chain extension which can be attached to the halter under the horse's chin, or the chain may be run through a side D and under the horse's chin. Chains are not permitted over the horse's nose or in the horse's mouth. Bridles are not permitted.
7. Overall division placing will be determined by the composite placing of all three classes.

## Yearling Longe Line

### Class Routine

1. The horses are to be shown in a flat nylon or leather halter, with a longe line 20 to 30 feet long. Use of a longe whip is optional. Longe whips may not have any type of attachment, such as a flag.
2. The arena will have a designated exhibition area. No assistance may be provided by grooms, once a horse enters the arena.
3. Each 4-H'er will have 2 minutes to exhibit his or her yearling. A whistle or announcement will signal the end of the 2-minute exhibition. At the completion of the 2 minutes, the 4-H'er and the horse will leave the working area. After all horses are worked, they will be brought back in and lined up for a final inspection.
4. Yearling longe line horses should be shown in both directions on the longe line and should attempt to show all three gaits in each direction. The order in which the gaits are shown is the choice of the exhibitor. Failure to show all three gaits shall not be cause for disqualification, but shall be scored accordingly.
5. Longe whips, if carried, should be used to provide encouragement and to aid in positioning the horse on the longe line. Excessive use of the longe whip can be cause for **disqualification**.

### Scoring

1. One or two judges will be used. If two judges are used, their scores will be added together. If possible, judges who will not be judging the halter futurity will be used to judge the longe line class.

Scoring will be computed as follows:

- a. 40 percent for mechanical correctness of longeing procedures and the response of

- the horse on the longe line.
- b. 40 percent for quality of movement.
  - c. 20 percent for conformation.

## Yearling Showmanship

### Horse Fitting and Grooming

1. The horse should be clean and well-groomed. Manner of fitting for mane and tail may vary according to recognized breed and discipline standards. Hair coat should be clean, shiny and should show evidence of frequent grooming. Underweight or thin horses will be penalized.
2. A well groomed horse that is clean, properly trimmed, and conditioned does have a justified advantage in showmanship at halter.

### Class Routine

1. Walk, trot, turn, stop, back, and pose the horse as shown in the posted pattern or by the judge's instructions.
2. The horse is always led from the left side. The exhibitor's right hand is held closest to the halter, with the distance being highly dependent upon the mannerisms of the horse, the size of both the horse and the exhibitor, and breed standards. The excess amount of lead is folded or loosely coiled in the left hand and held about waist high. Never wrap the excess lead around the hand or make a coil so small that a sudden jerk could cause the lead to wrap around the hand.
3. At both the walk and the trot, the exhibitor's shoulder should be about even with the horse's throatlatch. In this position, the horse is beside the exhibitor, allowing the judge a clear view of the horse's travel. Movement at both gaits should be brisk and sharp, as opposed to slow and dull. Speed of travel is somewhat related to straightness of travel, and the slower a horse moves, the greater chance for deviation from a straight line of movement.
4. When leading to or from a judge or ring steward, stops and turns are very important. The exhibitor should always allow plenty of space between the horse and the judge. Stops should be executed squarely and without hesitation, as the stop is an important maneuver preceding a correct turn or reverse of direction.
5. Turns of more than 90 degrees should always be executed to the right. Pushing the horse away, rather than pulling the horse around, will allow more distance between the horse's and the exhibitor's feet. In addition, turning to the right allows the horse to use the right hind foot as a pivot point. The horse can then cross the left front foot over the right front to execute a very uniform and smooth turn. This results in the horse remaining in essentially the same tracks after the turn is completed and provides the judge a good view as the horse is walked or trotted away.
6. Class routines may require walking or trotting back into the lineup of horses. The exhibitor should lead all the way through the line, stop, reverse, and then lead into the line to set up. If asked to change positions in the line, back the horse out of the line, and approach the new position from behind.
7. Pose or set up the horse with its feet set according to its type or breed. Stock horse

breeds stand square. Move the horse's feet by pushing or pulling on the lead strap as necessary with the right hand. Touching the horse's body with a hand or foot to change the horse's position is penalized.

8. Once set up, the horse should be presented in such a way as to not distract the judge's attention from the horse. The exhibitor stands on the opposite side of the horse when the judge is toward the front and on the same side as the judge when the judge is toward the rear of the horse. This method of presentation is preferred by most judges for youth exhibitors.

9. For safety reasons, at no time should an exhibitor stop and stand directly in front of the horse.

10. The primary objective is to show the horse. Exhibitors should stand where they can see the judge and the judge can see them, but without obstructing the judge's view of the horse. The basic position of the exhibitor should allow constant observation of the horse's position and also permit observation of the judge.

11. Staring at the judge keeps an exhibitor from continually observing the horse and keeping the horse set properly. Exhibitors should maintain eye contact with the horse. It is acceptable to glance at the judge from time to time, but an exhibitor should NOT do this continuously.

12. Exhibitors should keep their proper position in line and allow reasonable space (at least 5 feet) between horses on either side. Keep horses from making contact with a competitor or encroaching on space rightfully belonging to another exhibitor.

#### Scoring:

1. Exhibitors will be scored from 0 to infinity with 70 denoting an average performance. Patterns will be divided into 6 to 10 maneuvers, as specified by the judge, and each maneuver will be scored from +3 to -3 with  $\frac{1}{2}$  point increments acceptable that will be added or subtracted from 70. Maneuver scores should be determined independent of penalties, and should reflect equal consideration of both performance of the exhibitor's pattern and form and effectiveness of the exhibitor to result in the following scores: +3 excellent, +2 Very Good, +1 Good, 0 Average or Correct, -1 Poor, -2 Very Poor, -3 Extremely Poor. Fitting and grooming of the horse should also be scored from 0 to 5 with 0 to 2 being Average, 3 Good, 4 Very Good, 5 Excellent.
2. Penalties:
  - a. 1 Point
    - i. Ticking or hitting an obstacle including cones, and plants
  - b. 3 Point
    - i. Break of gait at the walk or trot for 2 to 3 strides
    - ii. Severely disturbing obstacle
  - c. 5 Point
    - i. Not performing the specified gait or not stopping within 10 ft. of the designated area
    - ii. Over or under turning up to  $\frac{1}{4}$  turn
    - iii. Break of gait at the walk or trot for more than 3 strides
  - d. 10 Point
    - i. Exhibitor is severely and continuously out of position during inspection
    - ii. Excessive touching the horse or kicking or pointing at the horse's feet during set up
    - iii. Standing directly in front of the horse

- iv. Complete loss of lead shank
- v. Severe disobedience including rearing or pawing; horse continually circling exhibitor
- e. Disqualification
  - i. Loss of control of horse that endangers exhibitor, other horses or judge
  - ii. Failure to display correct number
  - iii. Willful abuse
  - iv. Excessive schooling or training; use of artificial aids
  - v. Illegal equipment
- f. Off pattern, including: wrong side of cone or marker; never performing designated gait; over or under turning more than  $\frac{1}{4}$  turn; must place below exhibitors who complete pattern correctly

### Yearling In-Hand Trail

The class will be judged on the performance of the yearling over obstacles, with emphasis on manners and way of going. Credit will be given to horses negotiating the obstacles with style, without hesitancy and willingly responding to the handler's cues. Horses shall be penalized for any unnecessary delay while approaching the obstacles. Judges should consider the overall appearance of the horse, conditioning and grooming, and the equipment (dirty, ill-fitting or ragged equipment should be penalized) in their overall scores. Also to be considered is the correctness of the horse while being led. Drifting to the side, leading or stopping crooked, failure to maintain a pivot foot in a turn, leading or turning sluggishly should be considered and evaluated in the horse's maneuver scores and reflected in his overall score. Handlers should be discouraged from excessive verbal cues and excessive stiff or unnatural movements around the horse or when leading.

### Class Routine

Yearling is to be led through the course with the exhibitor on the horse's left side. The exhibitor should be positioned between the eye and the midpoint of the neck. The exhibitor may change sides to negotiate obstacles.

### Scoring

3. Scoring will be on the basis of 0-infinity, with 70 denoting an average performance. Each obstacle will receive an obstacle score that should be added or subtracted from 70 and is subject to a penalty that should be subtracted. Each obstacle will be scored on the following basis, ranging from plus  $1\frac{1}{2}$  to minus  $1\frac{1}{2}$ :  $-1\frac{1}{2}$  extremely poor,  $-1$  very poor,  $-\frac{1}{2}$  poor, 0 correct,  $+\frac{1}{2}$  good,  $+1$  very good,  $+1\frac{1}{2}$  excellent. Obstacle scores are to be determined and assessed independently of penalty points. Penalties should be assessed per occurrence as follows:
4. Penalties:
  - a.  $\frac{1}{2}$  Point
    - i. Each tick of log, pole, cone, plant or obstacle
  - b. 1 Point
    - i. Each hit, bite or stepping on a log, pole, cone, plant or any component of the obstacle
    - ii. Incorrect or break of gait at walk or jog for two strides or less
    - iii. Both front or hind feet in a single-strided slot or space.
    - iv. Skipping over or failing to step into required space
  - c. 3 Points

- i. Incorrect or break of gait at walk or jog for more than 2 strides
    - ii. Knocking down an elevated pole, cone, barrel, plant or obstacle, or severely disturbing an obstacle unless caused by the tail
    - iii. Horse stepping outside the confines of, falling or jumping off or out of an obstacle with one foot once the foot has entered an obstacle; including missing one element of an obstacle on a line of travel with one foot. Handler may travel/stand inside or outside of the obstacle, as needed.
  - d. 5 Points
    - i. Dropping slicker or object required to be carried on course
    - ii. First or second cumulative refusal, balk, or evading an obstacle by shying or backing
    - iii. Letting go of gate or dropping rope gate
    - iv. Use of either hand to instill fear or praise (slight touching or tapping with one hand to cue horse in a sidepass maneuver only is acceptable)
    - v. Horse stepping outside the confines of, falling or jumping off or out of an obstacle with more than one foot once the foot has entered an obstacle; including missing one element of an obstacle on a line of travel with more than one foot. Handler may travel/stand inside or outside of the obstacle, as needed.
    - vi. Blatant disobedience (including biting, kicking out, bucking, rearing, striking or continuously circling exhibitor)
  - e. Disqualification
    - i. Loss of control of horse that endangers exhibitor, other horses or judge
    - ii. Fall of horse or handler
    - iii. Failure to display correct number
    - iv. Willful abuse
    - v. Excessive schooling or training; use of artificial aids
    - vi. Illegal equipment
  - f. Off Pattern; including: performing the obstacles other than in specified order, no attempt to perform an obstacle, third cumulative refusal, wrong side of cone or marker, never performing designated gait; over or under turning more than ¼ turn, must place below exhibitors who complete pattern correctly

### Obstacle Requirements

Course will include a minimum of 4 and a maximum of 8 obstacles. Below are examples of potential obstacles:

- Lead over at least four logs or poles. These can be in a straight line, curved, zigzag, or raised. The space between the logs is to be measured and the path the horse is to take should be the measuring point. Spacing for walkovers and trotovers should be as follows or increments thereof.
  - Walk-overs. The spacing for walkovers shall be 20" to 24" (50- 60 cm) and may be elevated to 12" (30 cm). Elevated walkovers should be set at least 22" (55 cm) apart.
  - Trot-overs. The spacing for trotovers shall be 3' to 3'6" (90- 105 cm) and may be elevated to 8" (20 cm).
- Chalk Circle. Requiring a turn on the haunches with hind feet inside and front feet turning outside the circle.
- Square, Lead into the square. While all four feet are confined in the square, make a 360 degree or less turn and lead out. Handler may remain inside or outside the square.
- Gate. It is permissible to carry excess lead in the right hand while negotiating the gate. Handlers losing control of the gate while passing through shall be penalized and scored accordingly.
- Back through. Shall consist of either Poles, Barrels or Cones

- Water Hazard. A ditch or shallow pond of water may be used. A horse must pass through this obstacle, which must be large enough so that to properly complete this obstacle all four feet of the horse must step in the water. Management may not place any item in the water. If a box is used, simulated water is permissible. If water is used, handler should walk to left of water while horse passes through water.
- Carrying Object. Any object, other than animal or fowl, and of a reasonable size or weight, may be carried to a specific point.
- Mailbox. Remove and/or replace items.
- Serpentine.
- Jog-through. Shall consist of poles L, double L, V, U or similar shaped obstacle. Handler may be inside or outside the jog-through.

## 2-Year-Old Futurity

1. All 2-Year-Old Futurity horses must be designated as a futurity project in 4HOnline and entered through the same process as the yearlings in the futurity horse program.
2. All horses in this class will be shown two-handed in a smooth snaffle bit or a bosal.
3. The 2-Year-Old Futurity Division will consist of three separate classes: 2-Year-Old Futurity Pleasure Pattern, 2-Year-Old Futurity Versatility, and 2-Year-Old Futurity Western Pleasure. At the State Show, only a limited number of riders will be called back for the Western Pleasure class, as this will be considered the finals of the 2-Year-Old Futurity.
4. Overall placing will be determined by the composite placing of all three classes.
5. All equipment and attire must conform to the specified rules and regulations.

### 2-Year-Old Futurity Pleasure Pattern

This class serves to measure the ability of the horse to be functional and a pleasure to ride while being used as a means of conveyance from one task to another. This horse should be well-broke, relaxed, quiet, soft, and cadenced at all gaits. The horse should be ridden on a relatively loose rein with light contact and without requiring undue restraint. Excessively long, floppy reins will not be given extra credit. The horse should be responsive to the rider and make all required transitions smoothly, timely, and correctly. The horse should be soft in the bridle and yield to contact.

Horses shall be shown individually at the walk, trot, and lope in both directions. The walk, trot, and lope will be extended in one direction only. Markers set up in the arena will designate gait changes. The pleasure course shall be set to make approximately one pass of the arena in each direction. The pattern may be started either in the left or right direction. The order of gaits shall be:

- 1) extended walk,
- 2) trot,
- 3) extended trot,

- 4) lope,
- 5) stop and reverse,
- 6) walk,
- 7) lope,
- 8) extended lope,
- 9) trot, and
- 10) stop and back.

### Description of Ideal Pleasure Gaits

See description of Ideal Pleasure Gaits in Stock Horse Pleasure.

### Scoring the 2-Year-Old Futurity Pleasure Pattern

This class will be judged and scored as the Stock Horse Pleasure Class, with the exception that the 5 point penalty for use of two hands will not apply when a snaffle bit or hackamore is used.

#### 2-Year-Old Futurity Versatility

1. The judge will ask each rider to work individually. Individual works will be a combination of maneuvers that the judge feels are necessary to determine the brokenness and manners of the horse/rider combination. The pattern must include only maneuvers from the following list:
  - a. straight walk, jog, and lope, and/or circles in both directions.
  - b. stop.
  - c. back straight, in an "L", and in a circle.
  - d. 360-degree turn or spin.
  - e. pivot, both ways.
  - f. turns of 90, 180 or 270 degrees.
  - g. rollbacks
  - h. lope circles of varying size and speed.
  - i. pick up leads from standstill, walk, or jog.
  - j. simple lead changes on a straight away or in a circle.
  - k. side pass.
  - l. trot around or through cones.
  - m. two track.
  - n. walking and/or trotting over logs.
2. The pattern should be posted at least 1 hour before the class begins, if at all possible.
3. Scores on individual works will be based on rider's skills, the brokenness/manners of the horse and execution of the pattern. Each maneuver will be scored from 1-10.

#### 2-Year-Old Futurity Western Pleasure

This class recognizes a horse for functional correctness, quality of movement, attitude, and manners. **At the State Show, only a limited number of riders will be called back for the Western Pleasure class, as this will be considered the finals of the 2-Year-Old Futurity.**

1. Horses are shown at a walk, jog, and lope on a reasonably loose rein without undue restraint. Horses must work both ways of the ring, at all three gaits, to demonstrate their ability with different leads and transitions. Riders may be asked to extend the jog at the judge's discretion. An extended jog is a definite two-beat lengthening of stride and covering more ground. Cadence and balance with smoothness is more essential than speed. Lope with forward motion will be the only gait recognized as a lope. Horses may be required to reverse at the walk or jog and to go from any gait to another gait at the discretion of the judge. For safety of the exhibitors, a reverse at a lope or extended jog shall not be called.
2. Horses should back easily and stand quietly.
3. Horses are to be reversed to the center of the arena.
4. Any portion of a class may be placed on the rail for extra work by the judge at any time.
5. At no time shall a fault-out system that results in exhibitors being eliminated individually be used. A positive approach should be used, the winners or finalists being announced and the remainder of the class being dismissed from the arena as a group. Individual horses should not be pulled off the rail while the class is being judged.
6. Entries shall be penalized for being on wrong leads, but not necessarily disqualified. Excessive speed and breaking gait are to be penalized. Horses with a low head carriage and/or head carriage behind the vertical and/or a sullen, lethargic, emaciated, drawn, or tired look will be penalized.
7. The class will be judged on the performance and condition of the horse at the discretion of the judge.

### 3-Year-Old Futurity

This class provides a more challenging project for older, more experienced 4-H'ers and to provide more opportunities for a wider range of youth from across the entire state. Rules for judging have been written to provide a more meaningful evaluation of 3-Year-Old Horse Projects and to promote overall "brokenness" of horses.

1. The 3-Year-Old Futurity Division is an advancement division to follow the 2-Year-Old Futurity Division.
2. All 3-year-olds must be designated as futurity projects in 4HOnline and entered through the same process as are 2-year-olds and yearlings in the futurity horse program.
3. All horses in this class will be shown two-handed in a smooth snaffle bit. Bosals are not permitted.
4. To emphasize the all-around, versatile horse, the class will consist of three separate parts (3-Year-Old Futurity Pleasure, 3-Year-Old Futurity Trail, and 3-Year-Old Futurity Reining) with the overall placing being determined by the combination of all three parts. There will be no working finals.
5. At the discretion of the judges, an exhibitor taking excessive time starting/completing a maneuver or who is unable to negotiate a maneuver may be motioned on to the next maneuver.

### 3-Year-Old Futurity Pleasure Class

This class serves to measure the ability of the horse to be functional and a pleasure to ride while being used as a means of conveyance from task to another. This horse should be well-broke, relaxed, quiet, soft, and cadenced at all gaits. The horse should be ridden on a relatively loose rein with light contact and without requiring undue restraint. Excessively long, floppy reins

will not be given extra credit. The horse should be responsive to the rider and make all required transitions smoothly, timely and correctly. The horse should be soft in the bridle and yield to contact.

Horses shall be shown individually at the walk, trot, and lope in both directions. The walk, trot, and lope will be extended in one direction only. Markers setup in the arena will designate gait changes. The pleasure course shall be set to make approximately one pass of the arena in each direction. The pattern may be started either in the left or right direction. The order of gaits shall be:

- 1) extended walk,
- 2) trot,
- 3) extended trot,
- 4) lope,
- 5) stop and reverse,
- 6) walk,
- 7) lope,
- 8) extended lope,
- 9) trot, and
- 10) stop and back.

The extended trot may be ridden with the rider either posting or standing in the stirrups to the front of the saddle. Holding the saddle horn is permissible, at the extended trot. The reverse may be executed in either direction.

#### Description of Ideal Pleasure Gaits

See description of Ideal Pleasure Gaits in Stock Horse Pleasure.

#### Scoring 3-Year-Old Futurity Pleasure

This class will be judged as the Stock Horse Pleasure Class, with the exception that the 5 point penalty for use of two hands will not apply when a snaffle bit is used.

### 3-Year-Old Futurity Trail Class

The trail class, as the name implies, tests the horse's ability to cope with many situations encountered in everyday work. The horse is ridden through a pattern of obstacles which should nearly approximate those encountered during the course of everyday work. The horse is judged on the cleanliness, neatness, and promptness with which the obstacles are negotiated, ability to negotiate obstacles correctly, and attitude and mannerisms exhibited by the horse while negotiating the course. Emphasis on judging should be on identifying the well-broke, responsive, well-mannered horse which can correctly negotiate the course. The object is not to

trap a horse, or eliminate it, by making an obstacle too difficult. All courses and obstacles are to be constructed with safety in mind so as to eliminate any accidents.

1. Course will include no less than six and no more than nine obstacles. It is mandatory that the horse be asked to walk, trot, and lope during the course.

Walk – can be part of obstacle score and scored with approaching obstacle.

Trot – at least 35 ft and scored with approaching obstacle.

Lope - at least 50 ft and scored with approaching obstacle and be lead specific.

2. Care must be exercised to avoid setting up of any obstacles that may be hazardous to the horse or rider.
3. No extra verbal instructions may be given to the exhibitors by management or a judge that is not written in course description.
4. Judges must walk the course. Judges may remove or change any obstacle they deem unsafe, non-negotiable, or unnecessarily difficult. If any time a trail obstacle becomes unsafe during a class, it shall be repaired or removed from the course. If it cannot be repaired and horses have completed the course, the score for that obstacle shall be deducted from all previous works for that class.
5. The course may be walked on foot by the exhibitor but no horse/rider exhibitors are allowed on the actual course after it has been set until their trail run begins.

### Trail Class Obstacle Requirements

1. Course must be designed using the mandatory obstacles and maneuvers plus optional obstacles. Combining of two or more of any obstacles is acceptable.
2. Prohibited obstacles: Tarps, water obstacles with slick bottoms, PVC pipe used as a jump or walk over, tires, rocking or moving bridges, logs or poles elevated in a manner that permits such to roll in a dangerous manner. Animals live or stuffed (Exception: animals which could normally be encountered in a ranch setting and which are not used in an attempt to “spook” a horse could be used.).
3. Mandatory obstacles or maneuvers:
  - a. Ride over obstacles on the ground – usually logs or poles. It is recommended that all three gaits (walk, trot, lope) be used; however, only two gaits are required.
    - Walk-Overs – Walk over no more than five logs or poles. The space between logs for walk-overs should be 20 – 24” apart and no more than 10” high. These can also be in a straight line, curved, zigzagged, or raised.
    - Trot-Overs – Trot over no more than five logs or poles. The space between trot-overs should be 36-42”. Poles may be elevated a maximum of 10”. These can also be in a straight line, curved, zigzagged, or raised.

- Lope-Overs – Lope over no more than five poles. The space between lope-overs should be 6' to 7'. Poles may be elevated a maximum of 10". These can also be in a straight line, curved, zigzagged, or raised.
- b. Opening, passing through, and closing gate. A gate should be used that will not endanger horse or rider and requires minimum side passing.
- c. Ride over wooden bridge. (Suggested minimum width shall be 36" wide and at least six feet long). Bridge should be sturdy, safe, and negotiated at a walk only. Heavy plywood lying flat on the ground is an acceptable simulation of a bridge.
- d. Backing obstacles – Backing obstacles are to be spaced a minimum of 28" spacing. If elevated, 30" spacing is required. Back through and around at least three markers. Back through L, V, U, straight, or similar shaped course. May be elevated no more than 24".
- e. Side-pass obstacle – Any object which is safe and of any length may be used to demonstrate responsiveness of the horse to leg signals. Raised side-pass obstacles should not exceed 12".

Optional obstacles: Following is a list of optional obstacles from which selections can be made, but not limited to:

- a) Jump - An obstacle whose center height is not less than 14" high or more than 24" high. Holding the saddle horn is permissible for this obstacle,
- b) Carry object from one part of the arena to another,
- c) Remove and replace materials from mailbox,
- d) Trot through cones – spacing to be minimum of 6',
- e) Cross natural ditches or up embankments,
- f) Step in and out of obstacle,
- g) Put on slicker or coat,
- h) Pick up feet,
- i) Walk through brush,
- j) Ground Tie,
- k) Lead at the trot.

### Scoring 3-Year-Old Futurity Trail

This class will be judged as the Stock Horse Trail Class, with the exception that the 5 point penalty for use of two hands will not apply when a snaffle bit is used.

## 3-Year-Old Futurity Reining

This class measures the ability of the horse to perform many basic handling maneuvers. The horse should guide willingly without undue resistance.

### Scoring 3-Year-Old Futurity Reining

The pattern is broken down into 8 maneuvers to be scored 0-10 points each. Incorrect maneuvers (such as over or under spinning, turning the wrong direction, etc.) will not be a disqualification but will be scored a zero (0) for that maneuver. This will penalize contestant who perform the pattern incorrectly, but will not eliminate them from placing in that class.

#### Pattern

The judge shall indicate with markers on arena fence the center of the pattern.

1. Enter arena at sitting trot.
2. Two-track left, straight trot, two-track right.
3. Move up to an extended trot.
4. Stop and back; make a 90° pivot (left).
5. Lope one (1) fast circle to the right, change leads.
6. Lope two (2) fast circles to left, change leads.
7. Continue around previous circle to the right but do not close this circle. Run up the left side of the arena past the center marker and do a left rollback using the wall for assistance.
8. Lope straight down wall; make right rollback using the wall for assistance.
9. Lope to middle of arena; stop.
10. Make two (2) spins each direction. Exit arena at a trot.

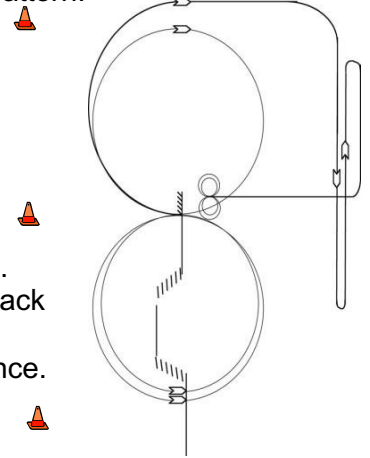

# Speed Events Division

The classes offered in this division are Pole Bending, Barrel Racing, and Stake Race. In all speed division classes, exhibitors have 2 minutes to enter the plane of the arena once called for their run. Failure to meet this time limit will result in disqualification.

## Pole Bending

1. The pole bending pattern is to be run around six poles. The poles are to be 21 feet apart, with the first pole 21 feet from the starting line.
2. A horse may start either to the right or to the left of the first pole and then run the remainder of the pattern accordingly (see the Pole Bending diagram).
3. Failure to follow the pattern shall cause **Disqualification**, Backing is considered a broken pattern
4. Knocking over a pole shall carry a 5 second penalty.
5. Pole bending is a timed event. Each contestant will begin from a running start. A clearly visible starting line should be provided. An electric timer should be used when possible. Otherwise, at least two watches should be used with the average time of the watches to be the official time.
6. In the event of a tie, the horse declared the winner in the runoff must run the pattern in no more than 2 seconds more than its original time, or the runoff must be held again.
7. It is recommended that all poles have at least a 14-inch base. Touching a pole with hand or body is NOT a disqualification.

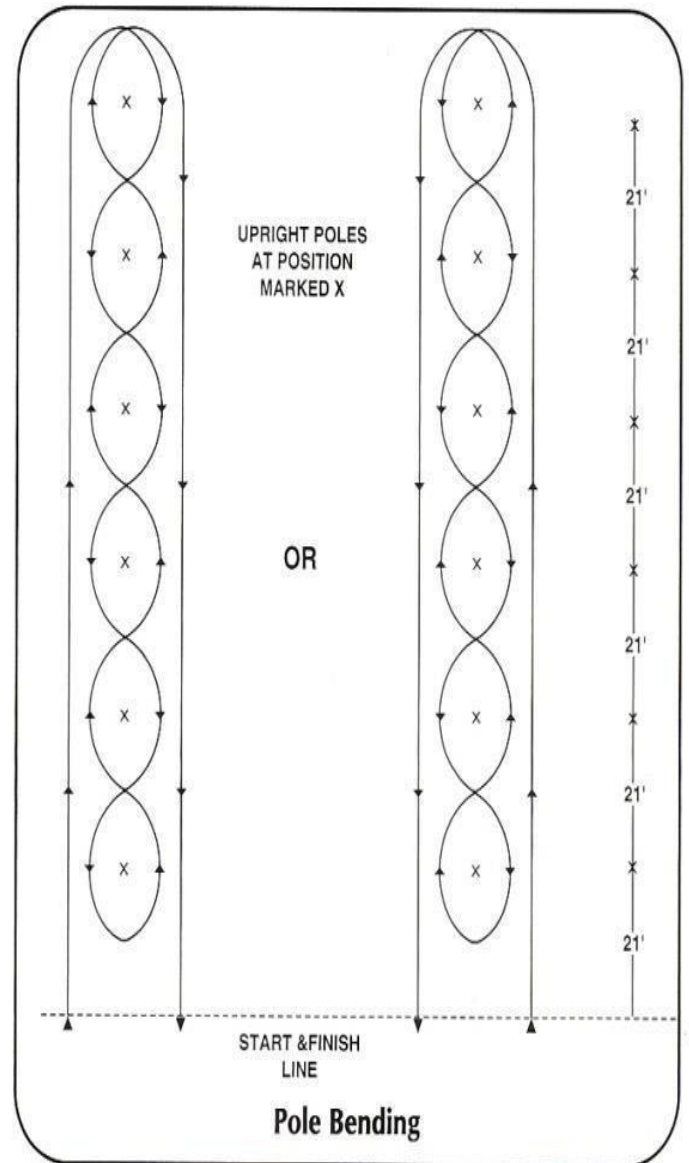

## Barrel Racing

1. Failure to follow the pattern is a **Disqualification**, backing is considered a broken pattern

2. Knocking over a barrel shall carry a 5 second penalty.

3. The course must be measured exactly. If the pattern is too large for the available space, the pattern should be adjusted by the show officials to fit the arena. Remember to leave adequate space between the barrels and the arena fence (approximately 20 feet), and set the course to allow ample room for stopping.

4. The barrel racing contest is strictly a timed event. An electric timer should be used for official time. If one is not available, the average time of at least two watches will be the official time.

5. In the event of a tie, the horse declared the winner in the runoff must run the pattern in not more than two seconds more than its original time, or the runoff must be held again.

6. The exhibitor is allowed a running start. Timing shall begin as soon as the horse's nose reaches the starting line and will be stopped when the horse's nose passes over the finish line.

7. At a signal from the starter or timer, the exhibitor will go to barrel number 1, turning to the right around this barrel, then on to barrel number 2, this time turning to the left. At barrel number 3, the exhibitor makes the same left turn around this barrel.

8. As soon as the turn is completed around the third barrel, the exhibitor sprints the horse to the finish line.

9. This barrel course may also be run to the left. For example, the exhibitor will start to barrel number 2, turning to the left around this barrel, then to barrel number 1,

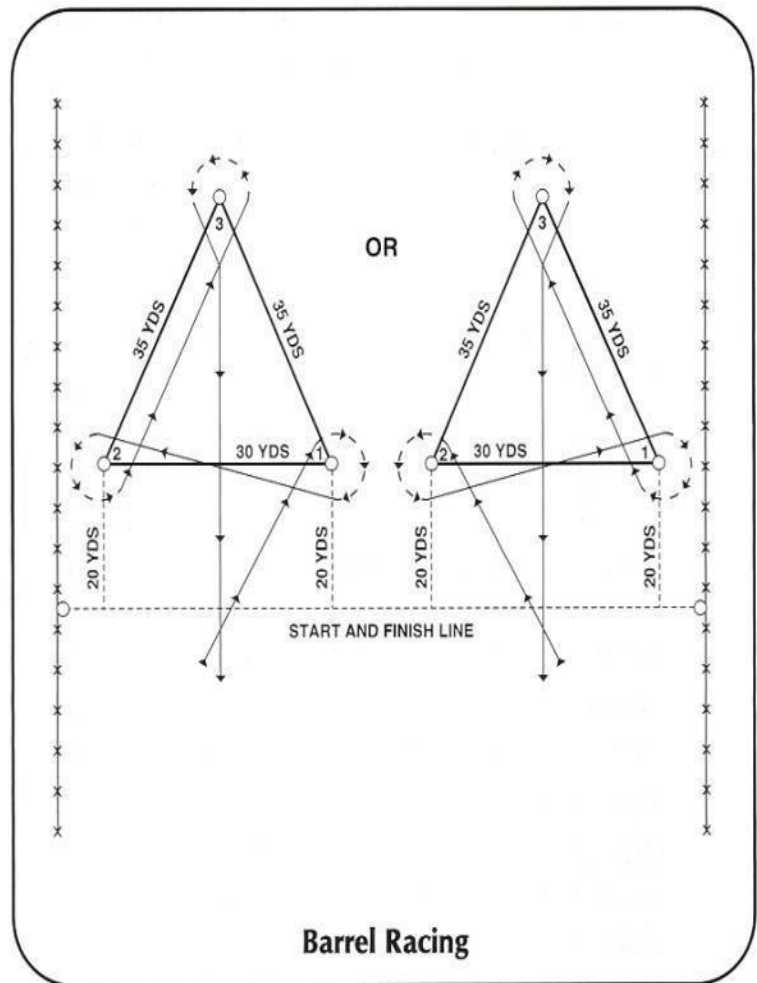

turning to the right, then to barrel number 3, turning to the right, followed by the final sprint to the finish line. (See barrel racing pattern.)

10. An exhibitor touching a barrel with hand or body is NOT a disqualification.

## Stake Race

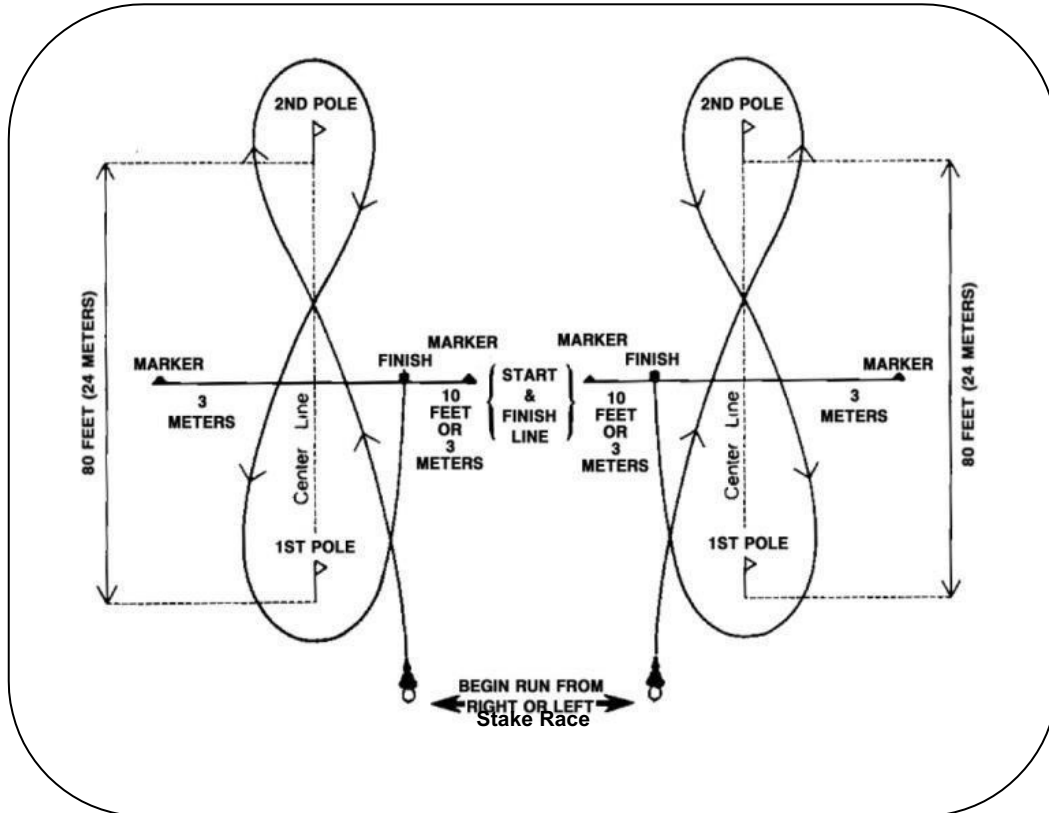

1. This is a timed event, run with the gate closed.
2. Two poles are set 80 feet apart at opposite ends of the course. Two markers designate the start-finish line 20 feet apart mid-way between the two end poles.
3. Timing shall begin as soon as the horse's nose reaches the starting line and will be stopped when the horse's nose passes over the finish line.
4. The exhibitor is allowed a running start and may begin the run from either the left or right side of the first pole. **Horses MUST start by crossing the center line between the upright markers, turn around the second pole, cross over the center line again between the markers, then around the first pole and run back across the finish line.**
5. Failure of an exhibitor to cross the start and finish line between the markers shall result in **NO TIME**.
6. Failure of an exhibitor to cross over the center line between the markers before turning the second pole shall result in **NO TIME**.
7. Backing is considered a broken pattern and will result in a NO TIME.

An exhibitor may touch the end pole(s) with his or her hand in the stakes race. Knocking over any of the poles or markers is a **NO TIME**. *At the State Show, exhibitors will ride to a closed gate.*

## Goat Tying

1. Goat Tying is a timed event. Starting line will be the timer. Starting line will be no closer than 80ft from the stake.
2. Goat shall be staked with a rope at least 10 feet in length and goat holder must hold goat at full length of rope behind stake, until contestant passes timer. A collar will be used on goat.
3. Stake will be driven into ground so that none of it is visible.
4. Goat will be held until contestant passes the timer.
5. The contestant must be mounted and must ride from starting line to goat, dismount, throw goat by hand (if goat is down when contestant reaches it, the goat must be cleared of the ground) and tie any three (3) legs together with a string or pigging string, indicating tie is finished by a signaling of hands in air and then stand clear of goat.
6. Goat must remain tied for at least five (5) seconds. In the event, the goat breaks the tie, and comes loose, before the 5 second time limit is up, it will result in a no time.
7. 3 Legs must be crossed and tied, to qualify as a legal tie. Once contestant signals his/her tie is complete, contestant may not again touch the tie or goat. If the contestant does, it will result in a no-time.
8. Time will start when the mounted contestant crosses the starting line (timer) and will stop when flag judge signals the completion of the tie.
9. Goat will be changed a minimum of every 3 and a maximum of every six (6) contestants.
10. Goats will not exceed 75 pounds
11. Same flagmen will be used for the entire event.
12. If the goat breaks loose from stake, contestant may receive a re-run, at the judge's discretion.
13. A ten (10) second penalty will be applied if contestant's horse touches the rope or goat.

## Hunter-Flat Division

The classes offered in this division are Hunter Showmanship, Hunter Under Saddle, and Hunt Seat Equitation. A 4-H'er must show in at least one of these three classes at the District Show, in order to be qualified to enter all three of these classes at the State Show.

### Hunter Showmanship

1. Hunter Showmanship is a performance class. The horse is considered only as a means of displaying showmanship skills. Conformation is not judged, but condition and appearance are considered.
2. Personal attire is described in the section "Hunter Attire and Equipment."
3. Horses are to be shown in an acceptable hunter bridle or plain leather halter. No crops or bats are permitted.
4. The method of showing and scoring will be as described previously in Showmanship at Halter, with horses being shown according to breed-type standards.
5. Class routine may vary according to arena size and number of exhibitors.

### Hunter Under Saddle

1. Riders are encouraged to display their number on both sides of their saddle.
2. The class will be judged on the horse's functional correctness, way of going, manners, and condition.
3. Hunters under saddle should be suitable to purpose. They should move in a long, low frame and be able to lengthen their stride and cover ground, as in traversing hunt country following hounds. They should be obedient, alert, and responsive to their riders. Quick, short strides should be penalized. Horses that move in an artificial frame and are overflexed and behind the bit should be penalized. Judges should emphasize free movement and manners.
4. Horses enter the ring at a trot and are shown at a walk, trot, and canter, while light contact is maintained with the horse's mouth.
5. Horses must work both ways of the ring at all gaits, to demonstrate their ability with different leads, gaits, and transitions. Horses may change gaits at the flat-footed walk or the trot at the judge's discretion.
6. The judge may ask finalists to hand gallop but never more than eight horses to gallop at one time.
7. Horses should back easily and stand quietly. The judge may ask that only the finalists be backed.
8. Large numbers in the class will necessitate qualification heats to accommodate all horses.

9. After each heat, all horses should be brought to the center of the arena and the finalists identified. Any portion of a class or heat may be placed on the rail for extra work by the judge at any time.
10. Horses with a low head carriage and/or head set behind the vertical and/or a sullen, lethargic, emaciated, drawn or tired look will be penalized.

## Hunt Seat Equitation

### General

1. Riders are encouraged to display their number on both sides of their saddle.
2. Riders will be judged on their basic position in saddle, which includes position and use of hands, seat, feet, and legs, as well as the ability to control and show the horse.
3. Scores on individual works will be based on the rider's skills and execution of the pattern.
4. Riders will not be required to jump.

### Position

1. General appearance. The rider should have a workman-like appearance, with a light and supple seat. Hands should convey the impression of complete control should any emergency arise.
2. Hands. The hands should be over and in front of the horse's withers, the knuckles 30 degrees inside the vertical, with the hands making a straight line from horse's mouth to rider's elbow. The hands should not be held tightly together. The method of holding the reins is optional, and the bite of the reins may fall on either side, but it is more acceptable for the bite of the reins to lie on the off side. However, all reins must be picked up at the same time. The rider should maintain light contact with the horse's mouth at all times, except when standing still.
3. Reins. The rein of the snaffle bridle may be held either outside the little finger or between the third and little finger. The snaffle rein of the pelham or full bridle should be held outside the little finger and a curb rein between the third and little finger or between the second and third fingers. In either case, the reins should be picked up at the buckles by the right hand, then straightened and separated in the correct order by the fingers of the left hand, pulled taut, and adjusted to even pressure in both hands.
4. Basic position. The eyes should be up and the shoulders back. The toes should be out at an angle best suited to the rider's conformation; the ankles fixed in; the heels down; the calf of the leg in contact with the horse and slightly behind the girth. The iron may be either under the toe or the ball of the foot or slightly behind the ball of the foot.

### Position in motion

At the walk and slow trot, the body should be vertical; at the posting trot, inclined forward; at the canter, halfway between the positions for the posting trot and walk; when galloping, inclined forward the same as for the posting trot. **Class Routine**

Each rider will individually perform a designated pattern composed from the optional list of maneuvers below. The judge will score each rider on his or her execution of the pattern as influenced by riding skills. Failure to execute or complete the pattern will not be a disqualification but shall be scored accordingly. The pattern will include maneuvers from the following list, or any maneuvers that the judge feels are appropriate to test the horseman's ability:

- a. Execute a slow sitting trot, posting trot, and/or extended trot.
  - b. Back.
  - c. Walk from a gallop with the emphasis on hands.
  - d. Halt from a canter.
  - e. Figure eight at the trot demonstrating the proper change of diagonals. The rider should be on the left diagonal when trotting in a clockwise direction and on the right diagonal when circling counter-clockwise. On the left diagonal, the rider will sit in the saddle when the horse's left front leg is on the ground. On the right diagonal, the rider sits in the saddle when the horse's right front leg is on the ground.
  - f. Figure eight at canter demonstrating a simple change of leads. (A simple change of leads is one in which the horse is brought back into a walk or trot before being restarted in a canter on the opposite lead.) Begin figures at the center of the two circles, so that one change of lead is shown.
  - g. Ride without stirrups.
  - h. Maintain a counter-canter.
  - i. Demonstrate a half turn on forehand and/or half turn on haunches.
  - j. Simple change of leads on straightaway.
  - k. Drop and pick up irons
2. The pattern should be posted at least 1 hour before the class begins, if possible.
  3. The judge will use the individual work scores to determine the top riders who will be asked to work individually or on the rail. Selected riders (or all riders if the class is small) will be required to work on the rail to determine final placing.
  4. Rail work will include walk, trot, and canter in one or both directions of the ring at the discretion of the judge. A reverse should be executed by turning away from the rail.
  5. The riders may be requested to gallop in safe groups and/or perform additional tests.

## Scoring

1. Exhibitors will be scored from 0 to infinity with 70 denoting an average performance. Patterns will be divided into 6 to 10 maneuvers, as specified by the judge, and each maneuver will be scored from +3 to -3 with ½ point increments acceptable that will be added or subtracted from 70. Maneuver scores should be determined independent of penalties, and should reflect equal consideration of both performance of the exhibitor's pattern and the equitation form and effectiveness of the exhibitor to result in the following scores: +3 excellent, +2 Very Good, +1 Good, 0 Average or Correct, -1 Poor, -2 Very Poor, -3 Extremely Poor. Exhibitors overall horsemanship form and effectiveness should also be scored from 0 to 5 with 0 to 2 being Average, 3 Good, 4 Very Good, 5 Excellent. Exhibitors may also be judged on the rail, and their pattern score and/or ranking may be adjusted as appropriate.

## 2. Penalties

- a. 3 Points
  - i. Break of gait at walk or trot up to two strides
  - ii. Over/under turn of 1/8 to 1/4
  - iii. Tick or hit of cone
  - iv. Obviously looking down to check leads or diagonals
- b. 5 Points
  - i. Not performing the specific gait or not stopping when called for in the pattern within 10 feet of the designated location
  - ii. Missing a diagonal up to 2 strides in the pattern or on the rail
  - iii. Incorrect lead or break of gait (except when correcting an incorrect lead) at the canter
  - iv. Complete loss of contact between the rider's hand and the horse's mouth
  - v. Break of gait at walk or trot for more than two strides
  - vi. Loss of iron
  - vii. Head carried too low and/or clearly behind the vertical while the horse is in motion, showing the appearance of intimidation
- c. 10 Points
  - i. Loss of rein
  - ii. Missing a diagonal for more than two strides
  - iii. Use of either hand to instill fear or praise while on pattern or during rail work
  - iv. Holding saddle with either hand
  - v. Spurring or use of crop in front of girth
  - vi. Blatant disobedience including kicking, pawing, bucking and rearing
- d. Disqualification
  - i. Failure by exhibitor to war correct number in visible manner
  - ii. Willful abuse
  - iii. Excessive schooling or training
  - iv. Fall by horse or rider
  - v. Illegal use of hands on reins
  - vi. Use of prohibited equipment
- e. Off pattern, including: knocking over or wrong side of cone or marker; never performing designated gait, lead or diagonal; over or under turning more than 1/4 turn; must place below exhibitors who complete pattern correctly

## Hunt Seat Versatility

1. Horses to be shown in hunt seat tack and equipment. All equipment and rider attire rules for Hunter Under Saddle class will also apply to this class.
2. To be judged on the performance of the horse. Riders shall perform an individual pattern consisting of a series of maneuvers and the negotiation of obstacles such as logs, cones and cavallettis. **Required maneuvers** will consist of: walk, trot or canter over logs; sidepass over or between an obstacle; back through an obstacle such as an "L" or around a

series of cones or markers; show all three gaits (walk, trot and canter) sometime during the course of the pattern. **Additional maneuvers** which may be asked for include: trotting circles or figure-8's; cantering circles or figure-8's with a simple or flying lead change; trotting over elevated poles or cavallettis; **opening and closing a gate**; turns on the forehand or rearhand; extended gaits at the trot or canter; various gait transitions; and/or trotting around or through obstacles such as cones or other markers.

3. Patterns should be designed to give credit to the **forward-moving, hunter-type horses** in the class. **At the option of Show Management, finals may consist of rail work and/or additional pattern work.**
4. **The class will be judged on mannerisms, movement (consistent with hunter-type horses), responsiveness to the rider, and performance in negotiating the required maneuvers.** Scoring system to be used will be the same as Western Trail, with each maneuver scored +1½ to – 1½ with penalties applied, as in Western Trail. Incorrect diagonals will be assessed in maneuver score.
5. Points earned in this class will count for High-Point Hunter Horseman-Flat Division.
6. The overall objective for this class is to promote the more broke, versatile English horse which can perform maneuvers other than showing on the rail, with the intent that these horses could eventually progress to show in over-fences classes.

## Hunter Over Fences Division

The classes offered in this division are Working Hunter, Hunt Seat Equitation Over Fences, Hunter Hack, and Open Jumping. Should Junior and Senior Classes be combined, the fence heights will be set by the Junior minimum and maximum heights.

At the State 4-H Horse Show there will be a warm-up for the over fences classes. The number of horses allowed in the arena at a time will be determined by the number of entries in the show.

Resuming the course after a knockdown, if the fence must be jumped again on course, the jump will be reset. If the flag, standard, wing or obstacle has not been reset when the competitor is ready to jump, he must await the signal to start or be eliminated.

## Hunter Hack

1. Riders are encouraged to display their number on both sides of their saddle.
2. Horses will be judged on way of going, manners, even hunting pace, and jumping style.
3. To begin the class, all horses will be required to complete two jumps, each a minimum of 2 feet and a maximum of 2 feet 9 inches in height for the Senior Division and a minimum of 2 feet and a maximum of 2 feet 6 inches in height for the Junior Division. Jumps must be set at multiples of 12 feet apart at 36, 48 or 60 feet.
4. Horses being considered for an award may be brought back on the rail and shown at a

walk, trot, and canter both directions of the ring, at the discretion of the judge.

5. After the second fence, riders may be instructed to hand gallop and/or halt and back up.
6. Finalists may be asked to hand gallop, but never more than a safe number will be asked to gallop at one time.
7. Horses should back easily and stand quietly.
8. Ticks and jumping faults will be scored, as in the Working Hunter Class, at the discretion of the judge.
9. Placing for the class shall be determined by allowing a minimum of 70 percent for fence work and a maximum of 30 percent for work on the rail, if railwork is held. If railwork is not conducted, then placing for the class shall be determined by 100 percent fence work.

### Working Hunter

1. Riders are encouraged to display their number on both sides of their saddle.
2. Horses will be judged on performance, manners, hunting pace, style of jumping and way of moving, as well as suitability for actual use in the hunting field.
3. All horses must be serviceably sound. Exhibitors shall trot a soundness circle on a loose rein, immediately following completion of the course. Any horse showing lameness, broken wind, or impairment of vision shall be refused an award at the judge's discretion.
4. Each horse individually will negotiate a course of at least eight jumps with a minimum of four obstacles. At least one change of direction is required. The course should be posted 1 hour before the class. Judging will start when the horse enters the arena and will end when the horse leaves the arena.
5. Minimum height of fences will be 2 feet 6 inches; maximum height will be 3 feet 6 inches for the Senior Division and a minimum of 2 feet maximum of 3 feet for the Junior Division.
6. Management should provide at least one practice jump. This jump should be in a warm-up area or arena.
7. Jumps to be used may be selected from the following list but will not be limited to this list:
  - a. Brush.
  - b. Post and rail.
  - c. Gate.
  - d. Chicken coop.
  - e. Stone wall.
  - f. In and out: post and rails spaced 24 to 36 feet apart. (This should never be used as the first obstacle in the course.)
8. When designing a hunt course, space the jumps a minimum of 48 feet apart, with all intervals in multiples of 12 feet. The distance of take-off or landing from the jump usually ranges from a distance equal to the height of the jump to one-and-one-half times the height of the jump (for example, for a 3-foot fence, the take off point would be from 3 to 4 ½ feet from the fence).

9. Faults:

- a. An even hunting pace is required for a good performance. Excessive speed, breaking gaits, wrong leads, etc., will be penalized.
- b. Jumping form and style will be considered. Unsafe jumping will be penalized regardless of whether or not the jump was cleared.
- c. Light touches are not to be considered in the jumping, but may be recorded for reference in extremely close competition. Touching brush only on a brush jump is not to be scored as a touch.
- d. When a horse makes two faults at an obstacle, only the major fault on the top element will be scored. Refusals are cumulative and count in addition.
- e. When an obstacle contains more than one jump, horses are scored on each jump.
- f. In case of refusal or run-out on an obstacle that contains more than one jump, the contestant must re-jump the previous as well as the remaining jumps.
- g. Three cumulative disobediences, a fall of horse and/or rider, or going off course disqualifies the entry. Dismissed contestants will exit promptly.

10. The following point system may be used in scoring working hunter.

a. Knock-downs.

- i. With any part of the horse's body behind the stifle: 4 faults.
- ii. With any part of the horse's body in front of the stifle: 8 faults.
- iii. Of standard or wing in jumping obstacles with any part of the horse, rider, or equipment: 8 faults.
- iv. A horse's touching an obstacle, causing a rail of an adjoining panel or wing to fall, shall not be construed as a knock-down.

b. Disobediences.

- i. Circling once upon entering the ring and once upon leaving is permissible.
- ii. First refusal, run-out, bolting on course, extra circle, or showing an obstacle to a horse: 8 faults.
- iii. Second refusal, run-out, bolting on course, extra circle, or showing an obstacle to a horse: 8 faults.
- iv. Third refusal, run-out, bolting on course, extra circle, or showing an obstacle to a horse: **Elimination**.
- v. Jumping an obstacle before the reset: **Elimination**.
- vi. Bolting from the ring: **Elimination**.
- vii. Failure to keep proper course: **Elimination**.
- viii. Jumping an obstacle not included in course: **Elimination**.

c. Scoring shall be on a basis of 0-100, with an approximate breakdown as follows:

- i. 90-100: an excellent performer and good mover that jumps the entire course with cadence, balance, and style.
- ii. 80-89: a good performer that jumps all fences reasonably well; an excellent performer that commits one or two minor faults.
- iii. 70-79: the average, fair mover that makes no serious faults, but lacks the style, cadence and good balance of the scoper horses; the good performer that makes a few minor faults.

- iv. 60-69: poor movers that make minor mistakes; fair or average movers that have one or two poor fences but no major faults or disobediences.
  - v. 50-59: a horse that commits one major fault, such as a hind knockdown, refusal, trot, cross canter, or drops a leg.
  - vi. 30-49: a horse that commits two or more major faults, including front knockdowns and refusals, or jumps in a manner that otherwise endangers the horse and/or rider.
11. 10-29: a horse that avoids elimination but jumps in such an unsafe and dangerous manner as to preclude a higher score. In working hunter classes, all horses work one go-round.

## Open Jumping

1. Riders are encouraged to display their number on both sides of their saddle.
2. Jumpers are scored and placed on a mathematical basis and penalty faults, which include disobedience, falls, and knock-downs. Time may be used to break ties in the second round.
3. Each horse individually will negotiate a course consisting of at least four different obstacles and make a minimum of eight jumps. Refer to Working Hunter Rule 7 for types of jumps.
4. Both a starting line (at least 12 feet in front of the first obstacle) and a finish line (at least 24 feet beyond the last obstacle) must be indicated by markers (at least 12 feet apart) at each end of the lines.
5. The height of all fences will be a maximum of 3 feet 6 inches (42 inches) in the first elimination round.
6. At least 50 percent of the jumps must be raised no less than 3 inches and no more than 6 inches for the second round. The first jump in each round should be no more than the minimum height used in the elimination round.
7. Horses with a clean first round will jump a second round with the course shortened and the round timed.
8. Jumpers will be scored as follows: when a horse commits two or more faults at the same obstacle, only the major fault, or only one in case of equal faults, will count except when a disobedience occurs. Disobediences are cumulative and faulted in addition to other faults occurring at the same obstacle.
  - a. **Knock-down:** When a horse attempts to jump an obstacle and knocks down the obstacle or any portion of it, the standard, or the wing with any portion of the horse, rider, or equipment, it is considered a knock-down and counts four faults, with the following exception, when a horse causes a knock-down while refusing, it is not to be faulted for a knock-down, but should be given only the correct amount of faults for the refusal.
  - b. **Disobediences:**
    - i. **Refusals.** When a horse stops in front of an obstacle (whether or not the obstacle is knocked down or altered), it is a refusal, unless the horse then immediately jumps the obstacle without backing one step. If the horse takes even

one step backwards, it is a refusal. If the horse is moved toward an obstacle after a refusal without attempting to jump, it is considered another refusal. In the case of a refusal on an in-and-out jump, the horse must return to the start of the in-and-out sequence and re-jump the previous as well as the following elements.

- ii. **Run-out.** A run-out occurs when a horse evades or passes the obstacle to be jumped; jumps an obstacle outside its limiting markers; or the horse or rider knocks down a flag, standard, wing, or other object limiting the obstacle (without jumping the obstacle).
- iii. **Loss of forward movement.** Failure to maintain a trot, canter, or gallop after crossing the starting line (except when it is a refusal, a run-out, or due to uncontrollable circumstances, such as when an obstacle is being reset) is a disobedience.
- iv. **Unnecessary circling on course.** Circling once upon entering the ring (prior to crossing the starting line) and once upon leaving is permissible. Any additional circling on the course or unnecessary showing of a fence to the horse is a disobedience.
- v. First disobedience (anywhere on course): 3 faults.
- vi. Second disobedience (anywhere on course): 6 additional faults. Third disobedience (anywhere on course): **Elimination.**
- vii. Fall of horse and/or rider: **Elimination.**
- viii. Failure to complete course, off course: **Elimination.**
- ix. Jumping an obstacle before it is reset or without waiting for the signal to proceed: **Elimination.**
- x. Starting before the judge's audible signal to proceed; jumping an obstacle before the start or after crossing the finish line, whether forming part of course or not; jumping obstacles out of order; off course: **Elimination.**
- xi. Failure to enter ring within 1 minute of being called: **Elimination.**
- xii. Failure to cross the starting line within 1 minute after the judge's audible signal to proceed: **Elimination.**
- xiii. Jumping any obstacle before crossing the starting line unless the obstacle is designated as a practice jump: **Elimination.**
- xiv. In cases of broken equipment, the rider either may continue without penalty or be eliminated. If a shoe is lost, the rider may continue without penalty or be eliminated.

## Hunt Seat Equitation Over Fences

1. Riders are encouraged to display their number on both sides of their saddle.
2. The rider's performance and skills over fences are being judged in this class: the rider's basic position in the saddle; the position and use of hands, legs, and feet; the ability to control and show the horse.
3. Each rider shall perform a pattern consisting of at least six jumps. Three cumulative refusals will cause elimination. Maximum fence heights and types of fences shall be like those listed in Working Hunter rules.
4. Position: Same as Hunt Seat Equitation.
5. The judge will score each rider on his or her individual skills and execution of the pattern.

The top riders may be required to work on the rail to determine the final placing.

## Roping Division

### General Rules

1. All roping events will be timed. **All runs must be completed within 30 seconds for the Senior Division and within 45 seconds for the Junior Division.**
2. Equipment: See Timed Event Class Equipment. ***Long-sleeved shirts are required.***
3. One official will be designated as barrier judge and one official will be designated as official flagman.
4. All exhibitors must start from behind an electric eye barrier; however, in the event of equipment failure a rope barrier, or other fair start method may be used at the discretion of show management. Breaking the barrier will result in a 10-second penalty added to the contestant's time. Length of score will be determined by arena conditions.
5. Any unruly horse or horse considered unsafe to either the contestant or the arena help may be dismissed from the competition. Horses are expected to be able to enter the box and wait for the barrier to be set. Decisions on such matters are made by show management personnel in charge of the roping events and are not subject to protest.
6. All claims of "foul" by barrier or gateman must be declared prior to contesting the cattle.
7. All cattle must be roped before they exit the arena.
8. All decisions of the officials are final and not subject to protest.
9. **All horses and contestants must be eligible according to the Texas State 4-H Horse Show rules.**
10. Final placings are determined from an average on 3 head.

### Tie-Down Calf Roping

1. All exhibitors in this event must use a neck-rope. Use of keepers and jerk lines is optional.
2. Exhibitors may throw two loops, provided the second rope is carried. Exhibitors may NOT recoil the rope for a second loop.
3. If the calf is down when the exhibitor reaches it, the calf must be gotten up prior to flanking and/or legging. If the roper's hand is on the calf when the calf falls, the calf is considered thrown by hand. (Note: Judge's ruling on these circumstances is not subject to protest).
4. The rope must hold calf until the roper gets their hands on the calf.
5. For a tie to be legal, the string must go around three legs at least one time and a half hitch.

6. The calf must stay tied for 6 seconds after the roper remounts and puts slack in the rope.
7. Only the roper may touch the calf. Any assistance will be a **disqualification**. Youth too small to throw and tie the calves should not enter this event. Based on the rules above, the officials shall have the authority to make judgments regarding any situation that might result in injury to contestants or livestock.
8. Any intentional dragging of calf, regardless of distance, will result in a **NO TIME**. Intentional dragging shall be defined as caused by contestant. Excessive dragging of calf will receive a **NO TIME**. Excessive dragging shall be defined as moving the calf six or more feet after the contestant has called for time. However, if in the opinion of the judge, the dragging was caused by something outside of the control of the contestant, the judge may give the contestant his time. Dragging the calf while the contestant is tying the calf will not be considered excessive dragging.

## Breakaway Roping

1. At the State Show, only one loop will be allowed.
2. A regular rope is tied to the saddle horn or swell with a breakable string. Time starts at the signal of the barrier flag and stops when the flagman signals that the rope breaks away from the saddle as a result of a legal catch.
3. Any unruly horse or horse considered unsafe to either the contestant or the arena help may be dismissed from the competition. Horses are expected to be able to enter the box and wait for the barrier to be set. Decisions on such matters are made by show management personnel in charge of the roping events and are not subject to protest.
4. The only legal catch is a clean bell collar loop that causes the string to break away from the saddle horn. A bell collar catch is defined as the looping passing over the head of the calf, ahead of the tail and no feet or legs in the loop.
5. Judges will rule whether a catch is legal and whether the rope breaks away as a result of a legal catch, or as a result of the horse or calf stepping on the rope or similar occurrence. The exhibitor will be given a **NO TIME** when something other than a legal catch causes the rope to break away.
6. A piece of cloth should be attached to the tail of the rope to signal when the rope breaks.

## Heading

1. This will be timed event. Time starts with the release of the barrier and ends when the ropes are tight and the horses have faced each other.
2. Legal head catches are both horns, half-head, and around the neck. A 5-second penalty will be assessed for roping only one hind foot. Illegal catches will be scored as a **NO TIME**. Illegal catches include a figure-8 head catch, hondo on one horn, and one or both front feet in the head or heel loop.
3. The direction of the steer's body must be changed before the heel loop can be thrown. Any loop thrown before the completion of the initial switch will be considered a crossfire, and **NO TIME** will be recorded. However, if the steer stops or sets up before the switch, it must only be moving forward for the heel loop to be legal.

4. Contestants have the option of dallying or tying on their ropes.
5. Any unruly horse or horse considered unsafe to either the contestant or the arena help may be dismissed from the competition. Horses are expected to be able to enter the box and wait for the barrier to be set. Decisions on such matters are made by show management personnel in charge of the roping events and are not subject to protest.
6. A maximum of three loops is allowed for each team. Failure to complete requirements for time within this limit will result in **NO TIME**. The run must be completed in **30** seconds for Seniors and 45 seconds for Juniors.
7. Riders **MUST** remain mounted. Loss of the rope by either header or heeler is an automatic **disqualification**.
8. A 4-H'er enters as an individual and may enter only once. The partner can be any 4-H'er who also is entered in the roping division, regardless of age group. A 4-H'er may help as many times as desired. Points will be awarded **ONLY** to the person entered, not the helper.
9. Each roper in the class must meet eligibility requirements.

## Heeling

1. This will be timed event. Time starts with the release of the barrier and ends when the ropes are tight and the horses have faced each other.
2. Legal head catches are both horns, half-head, and around the neck. A 5-second penalty will be assessed for roping only one hind foot. Illegal catches will be scored as a **NO TIME**. Illegal catches include a figure-8 head catch, hondo on one horn, and one or both front feet in the head or heel loop.
3. The direction of the steer's body must be changed before the heel loop can be thrown. Any loop thrown before the completion of the initial switch will be considered a crossfire, and **NO TIME** will be recorded. However, if the steer stops or sets up before the switch, it must only be moving forward for the heel loop to be legal.
4. Contestants have the option of dallying or tying on their ropes.
5. Any unruly horse or horse considered unsafe to either the contestant or the arena help may be dismissed from the competition. Horses are expected to be able to enter the box and wait for the barrier to be set. Decisions on such matters are made by show management personnel in charge of the roping events and are not subject to protest.
6. A maximum of three loops is allowed for each team. Failure to complete requirements for time within this limit will result in **NO TIME**. The run must be completed in **30** seconds for Seniors and 45 seconds for Juniors.
7. Riders **MUST** remain mounted. Failure to remain mounted will result in a disqualification.
8. A 4-H'er enters as an individual and may enter only once. The partner can be any 4-H'er who also is entered in the roping division, regardless of age group. A 4-H'er may help as many times as desired. Points will be awarded **ONLY** to the person entered,

not the helper.

9. Each roper in the class must meet eligibility requirements.

## Ranch Roping

The goal of this class is to show the ability of the horse and rider's skill in handling cattle as if they were doctoring injured or sick cattle. Cattle should be handled as calmly and slowly as possible. The judge should judge this class as if the cattle belonged to him or her. Entry does not have to separate the cow from herd and should not receive credit for separation from herd. If the cow is separated from the herd there should be no running or cutting of the cow. This is a judged event with a 2 minute time limit. There shall be a 30 second warning given prior to the end of the run. The rope must be thrown and the contestant may rebuild and throw an unlimited number of loops. No credit will be given for additional loops after a successful catch of any part of the animal. The honda on the rope used must be of a breakaway design. Ropes may not be tied hard and fast to the saddle horn.

The exhibition area should typically be normal width of the arena (usually 100 to 150') by 45' – 75'. Show management or the judge may adjust the size of the arena to allow for the temperament of the cattle.

Horse and rider must start from an entrance gate which will be opposite from where a herd of calves/yearlings are held as with each bearing a number. The size of the herd will be at show management and the judges' discretion. A random draw will be used to select the calf to be roped, which will be announced to the contestant when the horse enters the arena gate.

The contestant should make a desired catch, position their horse in an appropriate manner and dally up. A desired catch is defined as one in which the animal is roped and the rope comes tight in front of the animal's shoulders. A catch of any other part of the animal shall be considered legal but the exhibitor will receive a penalty. When the calf breaks free from the honda, the Flag Judge will signal the end of the run. In order to receive a score, the exhibitor must have a dally (full wrap) in place at the time the animal breaks free from the Honda.

The show committee will provide 2-4 herd holders. The sole duty of the herd holders is to settle the cattle prior to the event and between runs.

If the exhibitor completes a legal catch (correct cow), but the honda breaks before a dally can be completed, then the exhibitor may reset within their time limit and try again. However, if the catch is illegal (wrong cow, more than one cow in loop) the rider may not start again. If the honda breaks prior to roping, the exhibitor may reset and proceed.

## Scoring

Scoring will be on the basis of 0 to 100, with 70 denoting an average performance. Each maneuver will be scored from a plus three to minus three in ½ point increments.

Maneuvers to be scored:

1. Ability to sort
2. Stopping
3. Ability to rope out of the herd without disturbing other cattle
4. Dallying
5. Ability to manage coils
6. Ability to manage rope and position of horse while dallying
7. Difficulty of a throw that results in a successful catch

Penalties

1. 1 Point Penalty
  - a. Loss of working advantage
2. 3 Point Penalty
  - a. Too much time in the herd without roping

- b. Loss of cow (re-cut in the herd)
- 3. 5 Point Penalty
  - a. Multiple loop run (penalty may be assessed for each rebuild with a maximum of 15 points taken).
  - b. Running/scattering of the herd
  - c. Blatant disobedience of the horse including kicking, biting, rearing or striking
  - d. Inability of the rider to efficiently recoil and build a loop after a miss
- 4. 10 Point Penalty
  - a. Roping any portion of the cow other than the head/neck
  - b. Blatant disobedience (kicking, biting, bucking, rearing, striking etc.)
- 5. 0 Score (disqualification)
  - a. Running into or over cattle
  - b. Schooling
  - c. Whipping or hitting horse with rope
  - d. Fall to ground of horse or rider
  - e. Loss of rope
  - f. Roping wrong cow
  - g. Roping more than 1 cow with the same loop
  - h. Excessive running of the cattle
  - i. Failure to catch
  - j. Failure to dally (full wrap)

## **Stock Horse Division**

The classes in this Division are Ranch Sorting, Working Cow Horse, Cow Boxing\*, Cutting, Reining, Stock Horse Trail, Stock Horse Pleasure, Stock Horse Horsemanship, and Stock Horse Showmanship.

**\*Cow Boxing, Western Heritage Sorting and Freestyle Reining do NOT count for High Point Stock Horseman.**

### Ranch Sorting

Ranch sorting is derived from the ranching practice of sorting cows from calves or steers from heifers where finesse, agility and cattle working skills excel. It is a fun competitive timed event that matches a two rider team against 11 head of cattle to be sorted in numerical order from one sorting pen to another. The most cattle sorted in the fastest time wins. The basic concept of ranch sorting is that there are ten numbered cattle, 0-9, and one unnumbered for a total 11 head at the beginning of a run behind a foul line in an arena with two people mounted on the other side of the foul line.

1. Ranch sorting will take place between two pens of approximately equal size with show management's option of working cattle back and forth or only one way. Two ranch sorting arenas may be placed side by side with odd numbered teams in one arena and even numbered teams in the other arena. If cattle are to be worked back and forth, they need to be moved to the opposite pen and back before each new herd entering the arena is worked. Recommended sorting area to be 50' - 60' in diameter with no 90 degree corners, i.e. 60' round pen or octagonal "stop sign" design.
2. The start foul line will be recommended as a 12' - 16' opening between the two pens.

There will be a 90, 75, or 60 second clock for each class, at the option of show management. The

official clock is the electronic display clock. The official time of each run is determined by the amount of time used until all 10 cattle are sorted or the time limit has expired. Time will continue until all cattle are sorted in the correct order or the time limit is reached, either of which becomes the official time for that team.

3. A lap timer is to be used in all sorting classes to break ties where the cattle count is equal in runs of less than 10 cattle sorted. The stop watch used for lap time purposes will also be the back-up timer in the event of a malfunction of the electronic display clock.
4. There will be a minimum of one official line judge, to be positioned evenly with the foul line.
5. All cattle will be bunched on the cattle side of the gate within the designated area before the time begins. At the conclusion of each run, the judge will designate the need to bunch cattle.
6. The judge will raise the flag to signal when the arena is ready. The flag will drop when the nose of the first horse crosses the start/foul line and the announcer will provide the number to be sorted first. The riders will be given their number instantly. Any delay in crossing the foul line may result in a "no-time" for the team. With particular interest, that no one or two cattle are isolated.
7. All cattle must have approved back numbers; neck numbers are not acceptable. The cattle are sorted in order. If any part of a numbered cow crosses the start/foul line prior to its correct order, then the team receives a no-time. If any part of a sorted cow re-crosses the start/foul line, the team will be disqualified. If any part of any unnumbered cow crosses the foul line before the tenth cow is cleanly sorted, it will result in a no-time.
8. The order of sorting is determined by the picking of a random number by the announcer/timer and then that cow must be sorted first. For instance, if 5 is drawn as the first number, 5 is sorted first, then cow 6 must be sorted, 7, 8, 9, 0, 1 and so on. A cow is considered sorted when the entire cow is completely across the start/foul line.
9. If there is a malfunction of the sorting pen or a numbered cow jumps any fence and either leaves the arena or ends up in the opposite pen, but did not pass through the gate, it will result in a re-ride for that team at the end of the herd (assuming it was not caused by roughing of the cattle). In the instance of a re-ride, exhibitors will receive a full (90, 75 or 60 second) clock, but the exhibitor's time cannot be improved. However, the number of cattle sorted during the allotted time can be improved. (Example: If a team had five head in 55 seconds (with a 60 second clock) when the cow jumped the fence, they would get a re-ride with the full 60 second clock. In the re-ride, the same team sorted ten head in 50 seconds. Their official time would be ten head in 55 seconds).
10. Should a herd be numbered incorrectly or have too many non-numbered cattle, the team(s) will receive a re-ride at the end of that set of cattle. If a team is given a number that has already been used within a given herd, a rerun must be given immediately, using the correct number within that same herd.
11. At the judge's discretion, if a re-ride is given because of un-numbered, injured or unfit cattle, the re-ride will occur immediately using the same numbered cattle once injured, unfit or un-numbered cattle are replaced.
12. Any unnecessary roughness to cattle or horses or unsportsmanlike conduct may

result in disqualification. Any excessive use of a whip, rope, crop, bat or reins anywhere on the horse will be cause for disqualification.

13. A snaffle bit, curb bit or hackamore may be used no matter the age of the horse and may be ridden two handed.
14. If held, the ranch sorting jackpot will be open to any exhibitor at the State 4-H Horse Show

### Western Heritage Sorting

\*This class does not count toward Hi Point Stock Horseman. For this class, all rules for Ranch Sorting will apply along with the following:

1. Limited to a trot or walk by the sorter: Loping after one stride by the sorter will result in a no time. The gate person can go at any speed to defend the gate as a defensive move however they cannot lope toward or into the herd to sort cattle.
2. Verbal noise, by either contestant, intended to influence the cattle is prohibited. Shouting by either rider to intimidate the cattle will result in a no time however, non-verbal noises such as whistling, clucking, slapping chaps, etc... are all common practices among cattlemen and are allowed. Artificial whistles are not allowed.

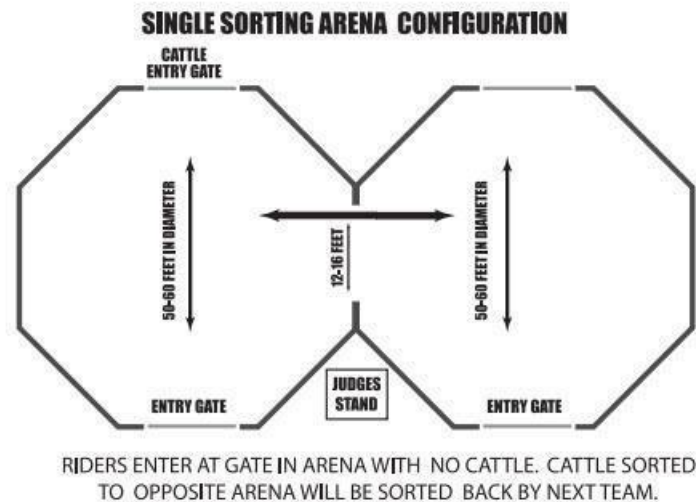

### Working Cow Horse

1. Both the cattle-work part of this event and the reining part are **mandatory**. Emphasis on cow-work scoring portion shall be based on the horse's maintaining control of the cow at all times, exhibiting superior cow sense, and natural cow-working ability, without excessive reining or spurring. Failure of an exhibitor to attempt to complete the cow-work portion of the class, as well as the reined work, will result in the exhibitor being **disqualified**.
2. **Exhibitors are being judged when they enter the arena.** Scoring will be on the basis of 60-80, with 70 denoting an average performance. The same basis of scoring shall apply to both the reined work and the cow-work.
3. Fall of the horse and/or rider while being shown in cow-work shall **eliminate** the entry.
4. Cattle work may be done immediately following each individual's pattern work or immediately

after the completion of pattern work by all horses being exhibited (at the discretion of the judge).

5. Horses must be aged 3 years or over to compete in Working Cow Horse

Prescribed Cow-Work

6. At the start of the cow-work portion, each contestant, upon receiving a cow in the arena, shall hold the cow on the prescribed end of the arena for a sufficient time. This demonstrates the ability of the horse to contain the cow on that end. After a reasonable amount of time, the contestant shall take the cow down the fence, making at least one turn each way on the fence. Then the contestant shall take the animal to an open part of the arena and take the animal in a circle at least once in each direction. This is ideal fence work; however, the judge should take into consideration the size of the arena, the condition of the ground, and the disposition of the cattle.

5a. If time and the number of cattle permit, the judge, at his or her discretion may award new cattle because:

- ⌘ The cow will not or cannot run.
- ⌘ The cow will not leave the end of the
- ⌘ arena. The cow is blind or will not yield to
- ⌘ the horse. The cow leaves the arena.

This is to enable the contestant to show their horse's ability on the cow.

**5b. It is the sole responsibility of the judge to award a new cow. Contestants MAY NOT request a new cow.**

6. The following characteristics are considered as faults:

- a. Exaggerated opening of mouth.
- b. Hard or heavy mouth.
- c. Nervous throwing of head.
- d. Lugging on bridle.
- e. Halting or hesitation while being shown, particularly when being run out, indicating anticipation of being set up, which is characteristic of an over-trained horse.
- f. Losing a cow or being unable to finish a pattern, because of a bad cow; the contestant shall be penalized at the judge's discretion.
- g. Touching the horse or saddle with the free hand, except during the cow-work portion of the class when the rider may hold onto the horn.
- h. A contestant's horse that turns tail on the cow shall receive a zero. Two hands on the reins, more than one finger between the reins, or changing hands on the reins shall constitute a zero.

7. The characteristics of a good working cow horse are:

- a. Good manners.
- b. Shifty, smooth movements with the horse's feet under him at all times; when stopping, hind feet should be well under him.
- c. A soft mouth that responds to a light rein, especially when turning.
- d. Head maintained in its natural position.

- e. Able to work at reasonable speed and still be under the control of the rider.
8. Specific penalties are as follows:
- a. **5-point penalties**
    - 1. Not getting one turn each way (5 points each way).
    - 2. Deliberate spurring or use of the romal forward of the cinch
  - b. **3-point penalties**
    - 1. Biting or striking the cow.
    - 2. Hanging up on the fence (refusing to turn).
    - 3. Exhausting or overworking the cow before circling.
    - 4. Knocking down the cow without having a working advantage.
  - c. **2-point penalty:** Going past the corner of the arena before turning the cow when going down the fence.
  - d. **1-point penalties**
    - 1. Loss of working advantage.
    - 2. Horses that run past the cow shall be penalized 1 point for every horse's length past the cow. When the horse's buttocks pass the cow's head by one horse's length, it is one length past.
    - 3. Failure to pass middle marker on first turn before turning cow.
    - 4. Using the corner or the end of the arena to turn the cow when going down the fence.
    - 5. Each time the arena is crossed to use the opposite fence to achieve a turn.
    - 6. Slipping a rein.
  - e. **0 score**
    - 1. Turn tail.
    - 2. More than one finger between the reins.
    - 3. Schooling between the reining pattern and cow work or schooling between cows, if a new cow is awarded.
    - 4. Leaving the work area before the pattern or work is complete:
      - a. Any horse that is out of control while working the cow, thus endangering the rider (such as crossing the path of the cow), shall be called off the cow.
      - b. Any horse that runs over the cow, thus causing the fall of horse and/or rider, shall terminate the work at that time.
    - 5. Use of two hands or changing hands on the reins.
    - 6. The judge may blow the whistle at any time to terminate the work.
    - 7. A score of 0 will be charged if the work is not complete at that point.
    - 8. Contestant should keep working until the judge blows the whistle. If the exhibitor quits working before the whistle, a score of 0 will be given in the cattle working portion.
    - 9. The judge should keep the safety and welfare of exhibitors, horses, and cattle in mind at all times. If any situation arises which endangers the rider, horse, or cow, the judge should terminate the run.

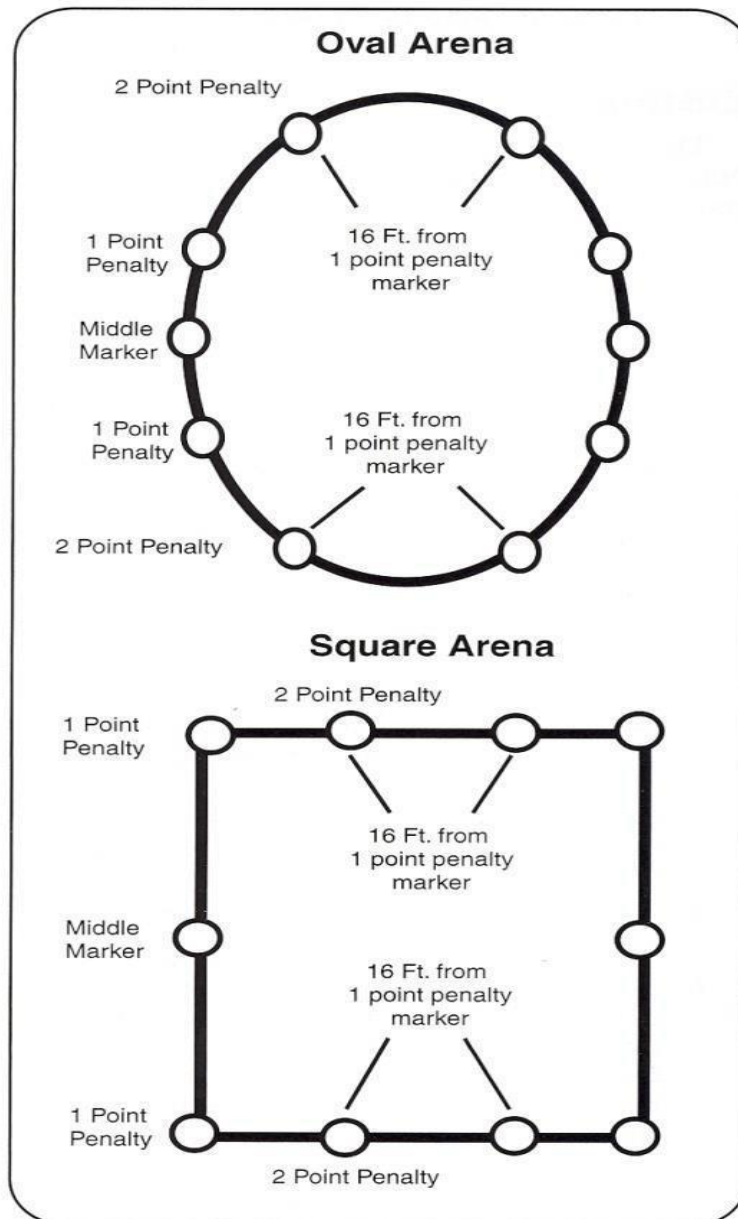

### Dry Work

One of the **five** patterns is to be selected by show management and used by all contestants in the class.

The approved patterns will be used, and each contestant will cause his or her horse to travel in the gait indicated for each part of the pattern. The bridle may be dropped at the judge's discretion.

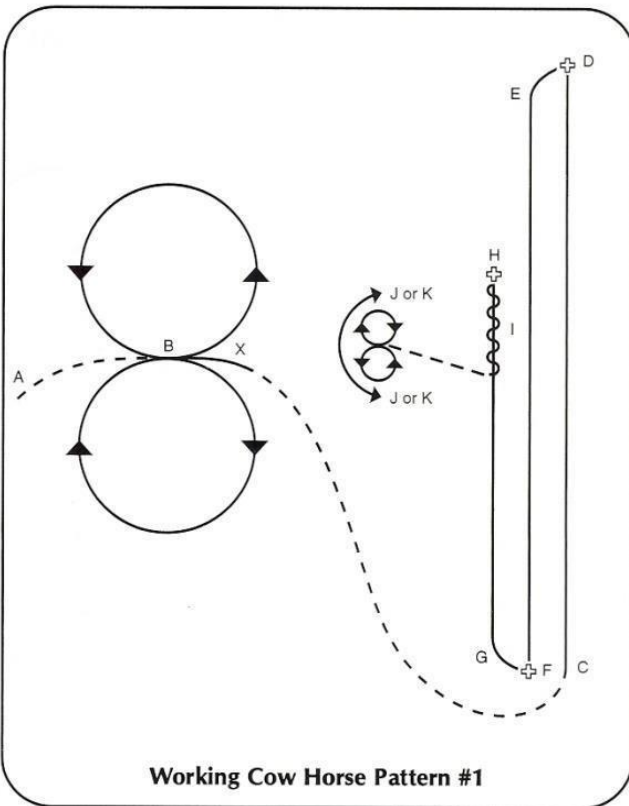

1. Begin work to the right.
  2. Figure eight; then, after the final lead change (before the point marked X) proceed to point C at a walk or trot.
  3. Begin a run. (C)
  4. Perform a sliding stop. (D)
  5. Turn away from the rail and begin a second run. (E)
  6. Perform a sliding stop. (F)
  7. Turn away from the rail and make a short run. (G)
  8. Perform a sliding stop. (H)
  9. Back up. (I)
  10. Do a 360-degree spin to the right or left. (J)
- Do a 360-degree spin (k) in the direction opposite to that taken in step 10.

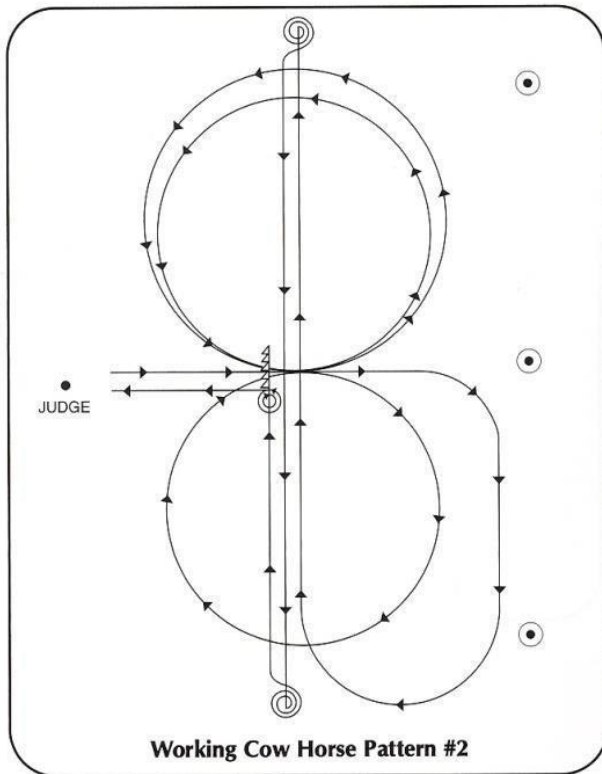

1. Begin at the center of the arena facing the right wall or fence. Begin on the right lead and complete a circle to the right away from the judge.
2. At the center of the arena, change leads, and do two circles to the left, approximately the same size.
3. At the center of the arena, change leads.
4. Go to the end of the arena, and without stopping or breaking gait, start the run near the approximate center of the arena. Run the full length of the arena.
5. Do a square sliding stop and hesitate.
6. Do two and one-half spins to the right.
7. Run the full length of the arena to a square sliding stop and hesitate.
8. Do two and one-half spins to the left.
9. Run past the center of the arena to a square sliding stop.
10. Back to the center of the arena (minimum 10 to 15 feet).
11. Do a 360-degree spin to the right or left.

Do a 360-degree spin in the direction opposite to that taken in step 11.

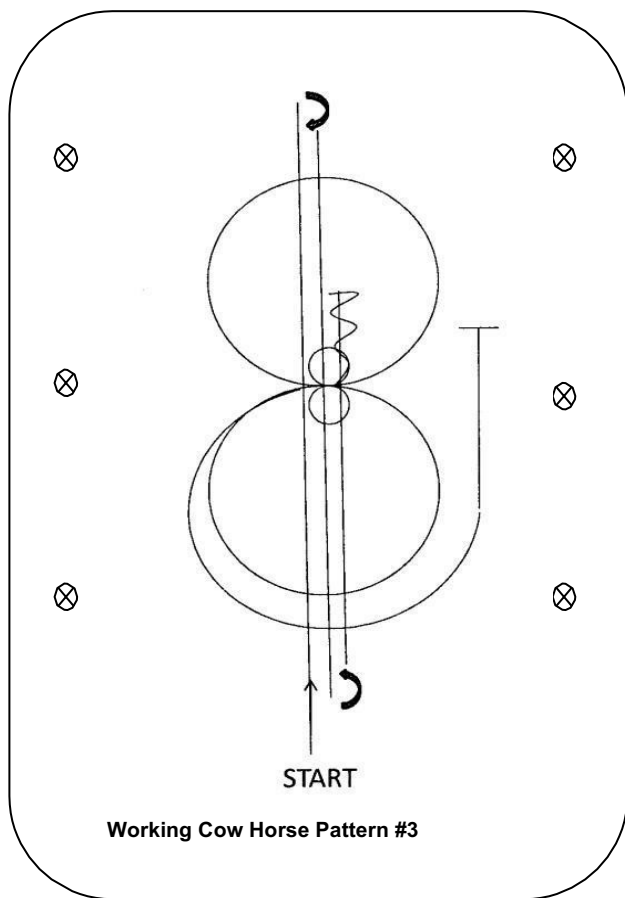

1. Begin the pattern with a run-down past the end cones.
2. Stop, perform a right rollback, and do a run-down to the opposite end of the arena.
3. Stop, perform a left rollback, and do a run-down past the center marker.
4. Stop, back up (at least 10 ft.), and turn 90 degrees to the left. Hesitate.
5. Do a 360-degree spin to the right.
6. Do a 360-degree spin to the left.
7. Beginning in the left lead, perform a large, fast circle to the left, and change leads.
8. Perform a large, fast circle to the right, and change leads.

Begin a circle to the left, but do not close the circle. Lope past the center marker, and stop.

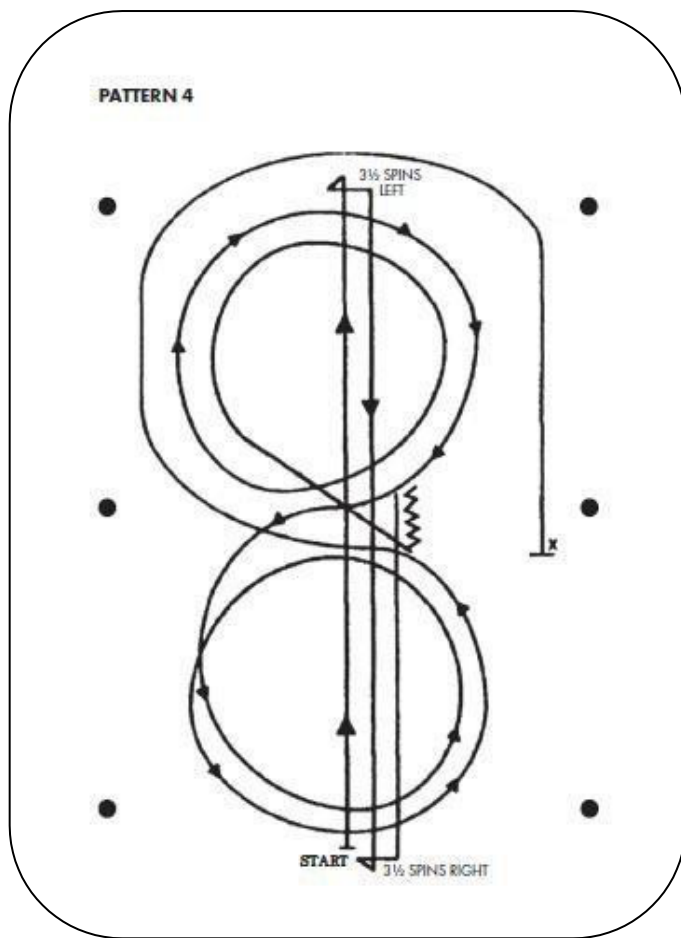

1. Start at end of arena.
2. Run up center of arena past the end marker and come to a sliding stop. Complete  $3\frac{1}{2}$  spins to the left.
3. Run to other end of arena past the end marker and stop. Complete  $3\frac{1}{2}$  spins to the right.
4. Run past the center marker and stop.
5. Back at least 10 feet in a straight line.
6. Complete a  $\frac{1}{4}$  turn to the left, hesitate. Beginning on the right lead, complete 2 circles to the right, the first one small and slow, and the second large and fast. Change leads at the center of the arena.
7. Complete one small, slow circle and one large, fast circle. Change leads to the right.
8. Run around end of arena to the other side, past center marker, at least 20 feet from fence and come to sliding stop. Hesitate to complete pattern.

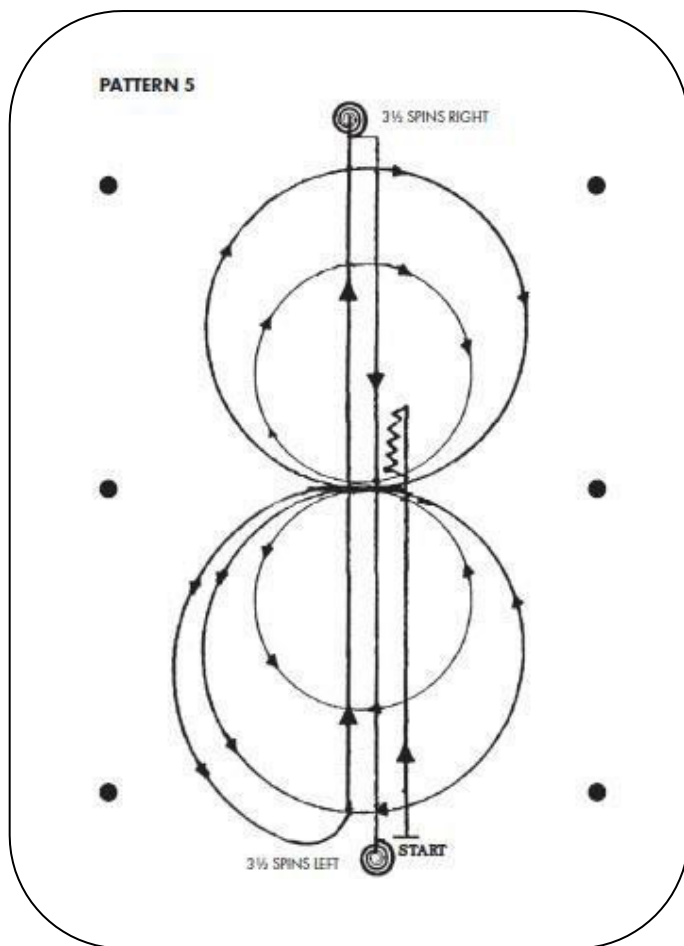

This pattern works best when the exhibitor and cattle enter from the same end of arena.

1. Start at end of arena. Run past center marker, stop, and back at least 10 feet.
2.  $\frac{1}{4}$  turn to left. Complete 2 circles to left. The first circle large and fast, the second circle small and slow. Change leads at the center of the arena.
3. Complete 2 circles to the right. The first circle small and slow, the second circle large and fast. Change leads at the center of the arena.
4. Continue around end of arena without breaking gait or changing leads, run down center of arena past end marker, execute a square sliding stop.
5. Complete  $3\frac{1}{2}$  spins to the right.
6. Rundown center of arena past end marker, execute a square sliding stop.

Complete  $3\frac{1}{2}$  spins to the left. Hesitate to complete pattern.

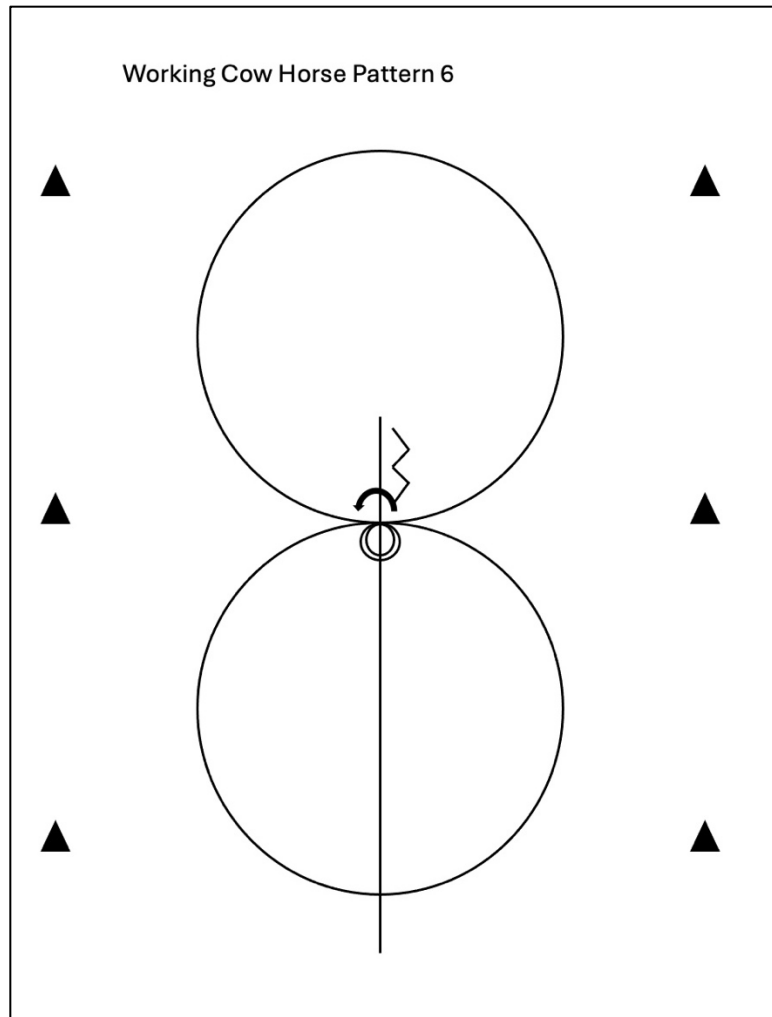

1. Run down center of arena past center marker, stop and back up. Hesitate.
2. Make a quarter turn to the left.
3. Lope a large, fast circle to the right. Change leads.
4. Lope a large, fast circle to the left.
5. Stop.
6. Complete two spins one direction. (Choose to spin two times to either the left or the right, your choice.)

## Cow Boxing

1. The Cow Boxing class is offered to encourage younger exhibitors or those who may be riding a less experienced cow horse, which are not ready to go down the fence, to show in a cow horse class.
2. **Exhibitors cannot show the same horse in the Working Cow Horse class and the Cow Boxing class at the State 4-H Horse Show. However they may show two different horses, one in Working Cow Horse and one in Cow Boxing. This class will not count for High Point Stock Horseman awards.**
3. **For this class only – horses can be shown in a snaffle bit with two hands on the reins or can be shown in a curb bit with only one hand on the reins.** (This applies to both the reining portion and cow work portion of the class).
4. The class will consist of dry work (pattern designated by the judge or show management) after which the contestant will ride toward the end of the arena to call for their cow. Upon the contestant's signal, the cow will be released and the contestant shall "box" the cow on the end of the arena.
5. Each contestant, upon receiving a cow, shall hold that cow on the prescribed end of the arena for 50 seconds, demonstrating the ability of the horse and rider to control the cow. It is legal to hold the saddle horn, and if using a romal, to hold the reins and romal in one hand (rein hand) while boxing. Time shall begin when the gate closes behind the cow, after being let into the arena. The announcer or judge will signal the completion of the 50 seconds with a whistle or horn.
6. Both parts of the class will be scored 60-80, with a 70 representing an average performance. Both scores will then be added together to place the class based on the combined score. Ties on total score will be broken by higher score on the cow work. The contestant is judged from the time they enter the arena until they complete the pattern. An entry which attempts both the rein work and the cow work portion may be placed, even if a 0 score is received in one portion of the class. (Example: If a horse is disqualified and receives a 0 score for the rein work, but scores a 70 for the cow work, its total score would be a 70 and the horse would be eligible for placing). The reining portion of the class will be scored the same as the regular Working Cow Horse reining pattern.
7. A judge may blow his/her whistle at any time to terminate the work. A score of zero will be given if the work is not complete at that time.
8. Specific penalties are as follows:
  - 1 point penalties:**
    - Loss of working advantage
    - Working out of position
    - Excessive whipping, spurring, or hollering
  - 3 point penalties:**
    - Loss of control and animal leaves the end of arena
  - 5 point penalties:**
    - Spurring or hitting in front of cinch at any time, Blatant disobedience, defined

as kicking, biting, bucking, rearing, striking, or obviously insubordinate

a. **-0- score:**

- A. Turn tail
- B. Using 2 hands on the reins when using a bridle or two rein
- C. Fingers between the reins, except when using a two rein
- D. Balking
- E. Out of control
- F. Bloody mouth (inside)
- G. Illegal equipment
- H. Leaving the work area before the pattern or work is complete
- I. Fall of horse or rider
- J. Schooling of the horse between the rein work and cow work
- K. Schooling of the horse between cows if a new cow is awarded
- L. Failure to pull up immediately after a new cow has been awarded
- M. Improper Western Attire
- N . Failure to work in the proper working order.
- N-E–Failure of an exhibitor to attempt to complete the pattern

b. **No Score**

- A. Lameness of the horse
- B. Abuse

**Credits:**

- A. Maintaining control of cow at all times
- B. Maintaining proper position
- C. Degree of difficulty
- D. Eye appeal
- E. Time worked

**Reminder: This class does NOT count for High Point Stock Horseman, and the same horse CANNOT be ridden in Cow Boxing that is ridden in Working Cow Horse.**

## Cutting

This class will be judged using the current National Cutting Horse Association scoring methods regarding penalties and credits.

1. A horse will be given credit for the ability to quietly enter a herd of cattle, make a deep cut, separate a cow from the herd, and set the cow up in the center of the arena.
2. Credit is given to a horse that works on a loose rein without being reined while working the cow. The degree of difficulty involved while working and eye appeal are factors considered for credit.
3. Penalties are assessed when a horse loses his working advantage and when a horse is reined or ridden on a tight rein.
4. Examples of penalties are back fence, hot quit, two hands on reins, horse quitting a cow, losing a cow, changing cattle after a commitment, turning tail to cow being worked, and
5. falling. The severity of these and other penalties are specified in the National Cutting Horse

Association rule book. Scoring ranges from 60 to 80 points, with an average performance being 70.

6. At the State Show, all contestants will show in the first go-round. **Top 15 and ties will advance to the finals, providing contestants scored a 121 or higher.** Only those scoring **a 121 or higher** will advance to the finals. Overall class awards will be based on the total of the preliminary score and finals score.
7. At the State Show, herd holders and turn back persons who are not exhibitors are NOT to ride any horse that is entered in any class not yet completed at the show. It is the responsibility of the exhibitor to arrange for herd holder and turn back help.

### Ranch Cutting

1. This class is judged on the ability of the horse to work a cow by separating it from the herd and holding it to demonstrate the horse's ability to work the cow. A single cow is cut from the herd and the horse must demonstrate its ability to work the cow. The ideal Ranch cutting horse should have a natural ranch horse appearance from head to tail in each maneuver.
2. Objective will be to cut two cows individually from the herd and work the cow(s) with the assistance of two turn-back riders and two herd holders.
3. There will be a two-minute time limit. Time will begin when a rider crosses a time line just prior to entering the herd. The announcer/timekeeper will give a warning when one minute of the two-minute working time has expired. Each exhibitor must work two head and has the option of ending their run before the two-minute limit or working the full two minutes.
4. Ultimate credit will be given to horses demonstrating excellence in the herd work by committing to, driving, setting up and working a cow in the center of the arena with minimal disturbance to the herd.
5. Exhibitors will not be penalized for reining but should display natural ability.
6. Scoring will be on the basis of 0 to 100, with 70 denoting an average performance.
7. Penalties will be assessed as follows:
  - a. **1 point:** over-bridled (per maneuver), out of frame (per maneuver), losing working advantage; toe, foot, or stirrup on the shoulder; working out of position
  - b. **3 points:** cattle picked up or scattered; spurring on shoulder; pawing or biting cattle; back fence; hot quit
  - c. **5 points:** horse quitting cow; losing cow; changing cattle after a specific commitment; failure to separate a single animal after leaving the herd; blatant disobedience
  - d. **Off Pattern (OP):** turn tail; failure to cut two cows; repeated blatant disobedience; use of two hands (except junior horses shown in a snaffle bit), more than one finger between split reins (except in the two-rein) or any fingers between romal reins
  - e. **Disqualification (DQ):** lameness; abuse; disrespect or misconduct; illegal equipment; excessive disturbance of herd to the point that exhibitor is asked to leave the arena; leaving arena before run is complete, fall of horse/rider; improper western attire

### Reining

1. Each contestant will individually perform the required pattern.
2. Each horse will be judged on the neatness, dispatch, ease, calmness, and speed with which it performs the pattern.
3. Excessive jawing, open mouth, or head raising on stop; lack of smooth sliding stops on haunches; breaking gaits; refusing to change lead; anticipating signals; stumbling or falling;

wringing tail; backing sideways; changing hands or reins; losing the stirrup; holding on to the saddle, two hands on reins; or any unnecessary aid (such as unnecessary talking, petting, spurring, quirting, jerking of reins, etc.) given by the rider to the horse to induce the horse to perform, will be considered a fault and scored accordingly.

4. The horse should rein and handle easily, fluently, and effortlessly and with reasonable speed through the pattern.
5. Any horse not following the pattern will be **disqualified**.
6. Scoring will be on the basis of 0 to infinity, with 70 denoting an average performance. **Judging begins when the horse enters the arena.**
7. Reining patterns 1 and 2 may be used at the State Show to determine those contestants who advance to the finals. Final placings are determined on cumulative score.

### Scoring

1. Scoring will be on the basis of 0 to infinity, with 70 denoting an average performance. The individual maneuvers are scored in  $\frac{1}{2}$  point increments from a low of  $-1 \frac{1}{2}$  to a high of  $+1 \frac{1}{2}$ , with a score of 0 denoting a maneuver that is correct with no degree of difficulty. Scores will be announced after each horse.
2. Any ties for the first place will be worked off, using the same pattern and order of go that was used during the event; however, there will be no more than one run-off. If the score remains tied after the run-off, the entrants will be named co-champions.
3. The following will result in **no score**:
  - a. Abuse of an animal in the show arena and/or evidence that an act of abuse has occurred before or during the exhibition of a horse in competition.
  - b. Use of illegal equipment, including wire on bits or curb chains.
  - c. Use of illegal bits or curb chains. Use of tack collars, tie downs, or nose bands.
  - d. Use of whips or bats.
  - e. Use of any attachment that alters the movement of or circulation to the tail.
  - f. Failure to dismount and/or present the horse and equipment to the appropriate judge or class superintendent for inspection, when requested.
  - g. Disrespect or misconduct by the exhibitor.
  - h. The judge(s) may excuse a horse at any time while in the arena for unsafe conditions or improper exhibition pertaining to both the horse and/or rider.
  - i. Excess rein may be straightened anytime during the pattern, provided the rider's

free hand remains behind the rein hand. Any attempt to alter tension or length of the reins from bridle to the rein hand is to be considered use of two hands and a penalty score of zero will be applied. In addition, should the judge determine the free hand is being used to instill fear or praise, a penalty five will be applied, and a reduction in the maneuver score.

4. The following will result in a **score of 0**:

- a. Use of more than the index or first finger between reins.
- b. Use of two hands, changing hands, or incorrect use of romal.
- c. Failure to complete the pattern as written.
- d. Performing the maneuvers other than in the specified order.
- e. The inclusion of maneuvers not specified, including, but not limited to:
  1. Backing more than 2 strides.
  2. Turning more than 90 degrees.
  3. Exception: a complete stop in the first quarter of a circle after a lope departure is not to be considered an inclusion of maneuver; a 2-point break of gait penalty will apply.
- f. Equipment failure that delays completion of pattern, including dropping a rein that comes in contact with the ground while the horse is in motion.
- g. Balking or refusal of command where pattern is delayed.
- h. Running away or failing to guide where it becomes impossible to discern whether the entry is on pattern.
- i. Jogging in excess of one half-circle or one-half the length of the arena.
- j. Over spins of more than  $\frac{1}{4}$  turn.
- k. Fall to the ground by horse or rider.

**Note: Neither a no score nor 0 is eligible to place in a go-round nor class, but a 0 may advance in a multi-go event, while a no score may not.**

5. The following will result in a penalty of **5 points**:

- a. Spurring in front of cinch.
- b. Use of either hand to instill fear or praise.
- c. Holding the saddle with either hand.
- d. Blatant disobedience including kicking, bucking, rearing, and striking.

6. The following will result in a **2 point penalty**:

- a. Break of gait.
  - b. Freezing up in spins or rollbacks.
  - c. On walk-in patterns, failure to stop or walk before executing a lope departure.
  - d. On run-in patterns, failure to be in lope before reaching the first marker.
  - e. If a horse does not completely pass the specified marker before initiating a stop position.
7. Starting or performing circles or figure eights out of lead will be judged as follows:
- a. Each time a horse is out of lead, a judge must penalize by **1 point**. The penalty for being out of lead is cumulative, and the judge will add **1 penalty** point for each  $\frac{1}{4}$  of the circumference of a circle or any part thereof that a horse is out of lead.
  - b. A judge is required to penalize a horse  $\frac{1}{2}$  **point** for a delayed change of lead by one stride.
8. Deduct  $\frac{1}{2}$  **point** for starting circle at a jog or exiting rollbacks at a jog up to two strides. For jogging beyond two strides but less than  $\frac{1}{2}$  circle or  $\frac{1}{2}$  length of arena, deduct **2 points**.
9. Deduct  $\frac{1}{2}$  **point** for over or under spinning up to  $\frac{1}{8}$  of a turn; deduct **1 point** for over or under spinning up to  $\frac{1}{4}$  of a turn.
10. In patterns requiring a run-around, failure to be on the correct lead when rounding the end of the arena will be penalized as follows: for  $\frac{1}{2}$  the turn or less, **1 point**; for more than  $\frac{1}{2}$  turn, **2 points**.
11. There will be a  $\frac{1}{2}$  **point** penalty for failure to remain a minimum of 20 feet from the wall or fence when approaching a stop and/or rollback.
12. The judge shall have the authority to remove any contestant from a show he or she is judging if the contestant shows any disrespect or misconduct as to render him- or herself or the show in an unprofessional manner.

Judges shall be the sole person(s) responsibility for determining if a rider has correctly completed the pattern.

## Reining Pattern #1

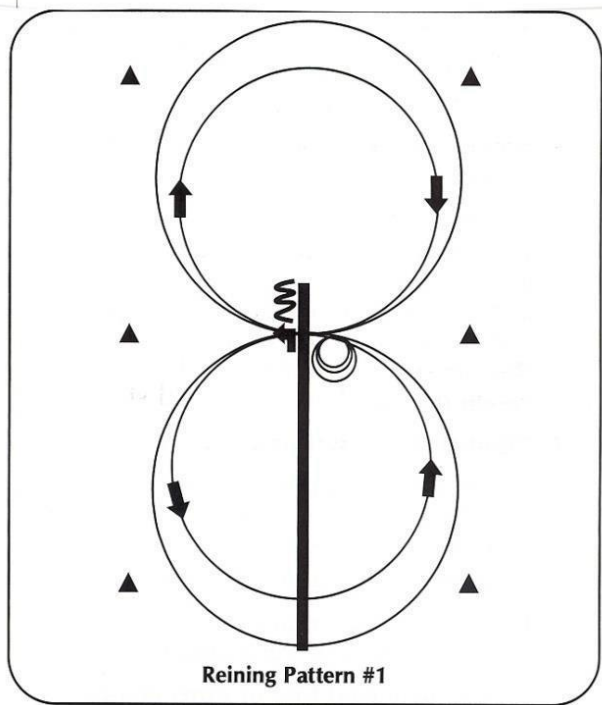

7. Run down center of arena past center marker, stop and back up. Hesitate.
8. Make a quarter turn to the left.
9. Lope a large, fast circle to the right, followed by a small, slow circle to the right. Change leads.
10. Lope a large, fast circle to the left, followed by a small, slow circle to the left.
11. Stop.
12. Complete four spins one direction. (Choose to spin four times to either the left or the right, your choice.)

Pattern complete. Exit the arena.

## Reining Pattern #2

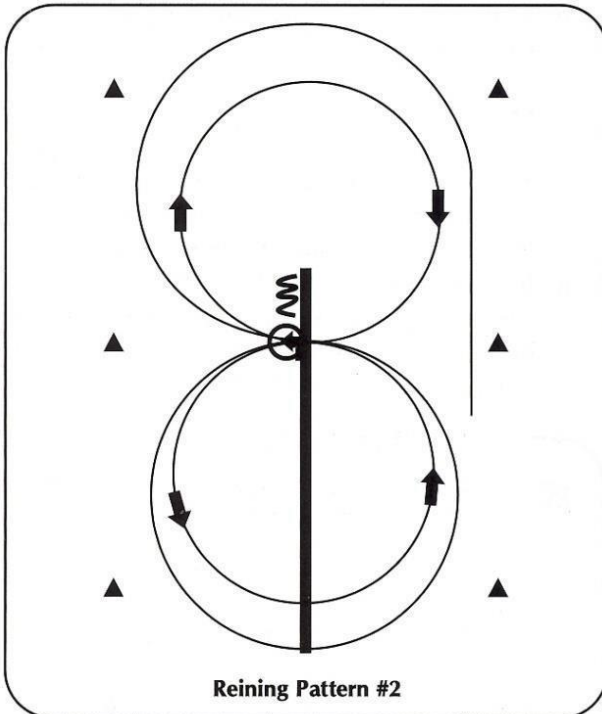

1. Run down center of arena past center marker, stop and back up. Hesitate.
2. Do four and one-quarter spins to the left.
3. Lope a small, slow circle to the left, followed by a large, fast circle to the left. Change leads.
4. Lope a small, slow circle to the right.
5. Begin a large, fast circle to the right, but do not close circle.
6. Run straight down the right side of the arena past center marker and stop.

Pattern complete. Exit the arena.

## Reining Pattern #3

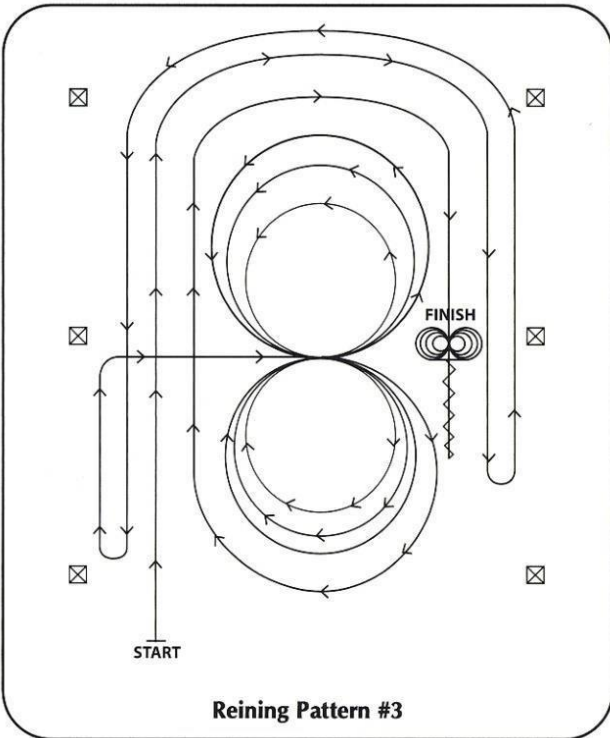

1. Beginning and staying at least 20 feet from the walls or fence, lope straight up the left side of the arena, circle the top end of the arena, run straight down the opposite or right side of the arena past the center marker, and do a left rollback – no hesitation.
2. Continue straight up the right side of the arena staying at least 20 feet from the walls or fence, circle back around the top of the arena, run straight down the left side of the arena past the center marker, and do a right rollback – no hesitation.
3. Continue up the left side of the arena to the center marker. At the center marker, the horse should be on the right lead. Guide the horse to the center of the arena on the right lead, and complete three circles to the right: the first two circles large and fast; the third circle small and slow. Change leads at the center of the arena.
4. Complete three circles to the left: the first two circles large and fast; the third circle small and slow. Change leads in the center of the arena.
5. Begin a large, fast circle to the right but do not close this circle. Continue up the left side of the arena staying at least 20 feet from the walls or fence, circle the top of the arena, run straight down the opposite or right side of the arena past the center marker, and do a sliding stop. Back up at least 10 feet. Hesitate.
6. Complete four spins to the right.

Complete four spins to the left. Hesitate to demonstrate completion of the pattern. Begin at the center of the arena facing the left wall or fence.

## Reining Pattern #4

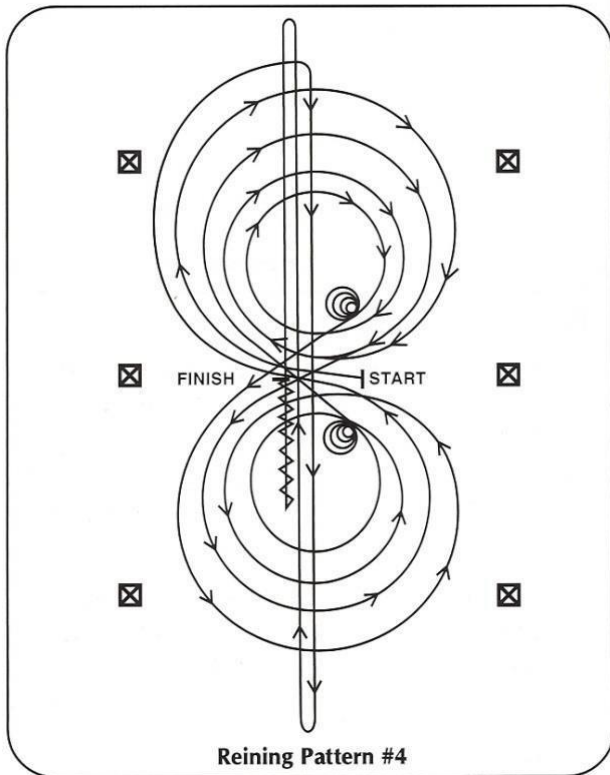

1. Beginning on the right lead, complete three circles to the right: the first two circles large and fast; the third circle small and slow. Stop at the center of the arena.
2. Complete four spins to the right. Hesitate.
3. Beginning on the left lead, complete three circles to the left: the first two circles large and fast; the third circle small and slow. Stop at the center of the arena.
4. Complete four spins to the left. Hesitate.
5. Beginning on the right lead, run a large fast circle to the right, change leads at the center of the arena, run a large fast circle to the left, and change leads at the center of the arena.
6. Continue around previous circle to the right. At the top of the circle, run down the middle to the far end of the arena past the end marker, and do a right rollback – no hesitation.
7. Run up the middle to the opposite end of the arena past the end marker, and do a left rollback – no hesitation.

Run past the center marker, and do a sliding stop. Back up to the center of the arena or at least 10 feet. Hesitate to demonstrate completion of the pattern.

## Reining Pattern #5

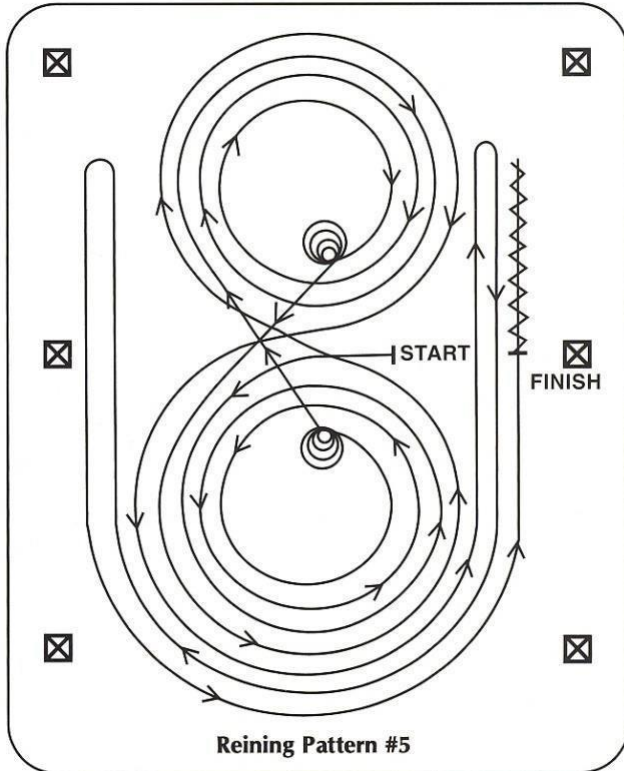

Begin at the center of the arena facing the left wall or fence.

1. Beginning on the left lead, complete three circles to the left: the first two circles large and fast; the third circle small and slow. Stop at the center of the arena.
2. Complete four spins to the left. Hesitate.
3. Beginning on the right lead, complete three circles to the right: the first two circles large and fast; the third circle small and slow. Stop at the center of the arena.
4. Complete four spins to the right. Hesitate.
5. Beginning on the left lead, run a large fast circle to the left, change leads at the center of the arena, run a large fast circle to the right, and change leads at the center of the arena.
6. Continue around previous circle to the left but do not close this circle. Run up the right side of the arena past the center marker, and do a right rollback at least 20 feet from the wall or fence – no hesitation.
7. Continue around previous circle to the right, but do not close this circle. Run up the left side of the arena past the center marker, and do a left rollback at least 20 feet from the wall or fence.

Continue back around previous circle to the left, but do not close this circle. Run up the right side of the arena past the center marker, and do a sliding stop at least 20 feet from the wall or fence. Back up at least ten feet. Hesitate to demonstrate completion of the pattern.

## Reining Pattern #6

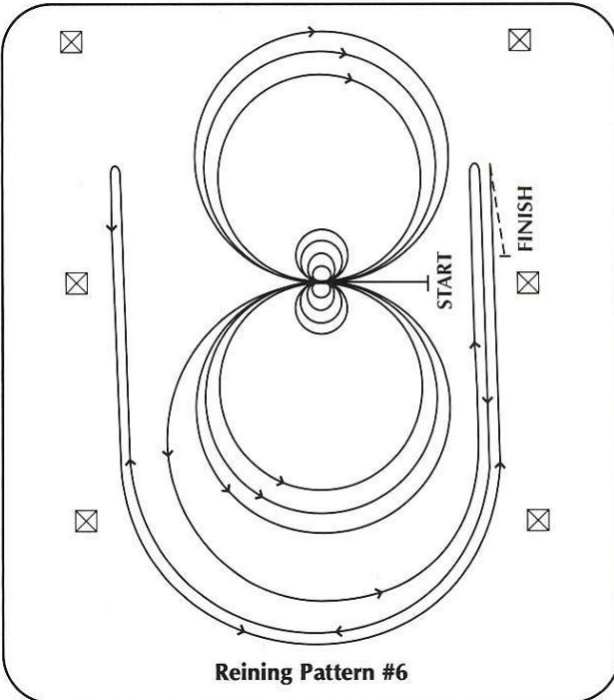

1. Walk to the center of the arena; the horse should be facing the left wall or fence.
2. Complete four spins to the right.
3. Complete four spins to the left.
4. Beginning on the left lead, complete three circles to the left: the first two circles large and fast; the third circle small and slow. Change leads at the center of the arena.
5. Complete three circles to the right: the first two circles large and fast; the third circle small and slow. Change leads at the center of the arena.
6. Begin a large fast circle to the left, but do not close this circle. Run up the right side of the arena past the center marker, and do a right rollback at least 20 feet from the wall or fence – no hesitation.
7. Continue back around the previous circle to the right, but do not close this circle. Run up the left side of the arena past the center marker and do a left rollback at least 20 feet from the wall or fence – no hesitation.
8. Continue back around the previous circle to the left, but do not close this circle. Run up the right side of the arena past the center marker, and do a sliding stop at least 20 feet from the wall or fence. Back up at least 10 feet. Hesitate, to demonstrate a completion of the pattern.

The bridle may be dropped at the judge's discretion.

## Reining Pattern #7

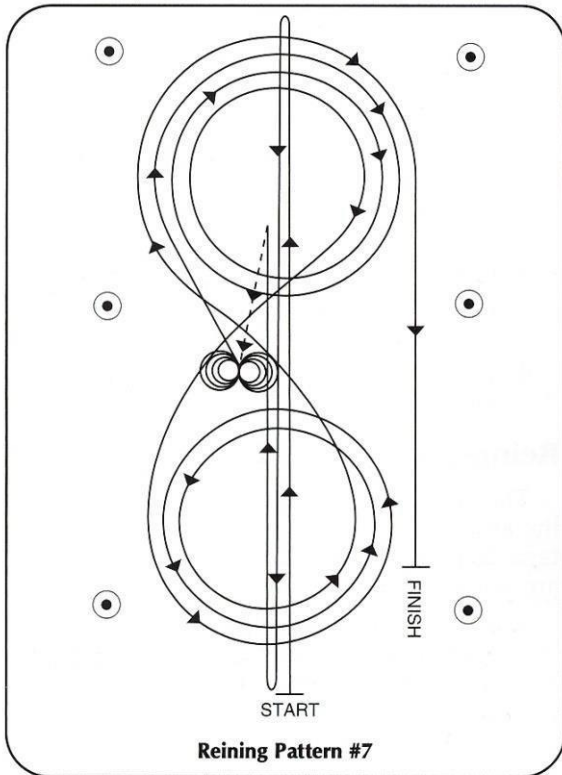

The judge shall indicate with markers on the arena fence or wall the length of the pattern. Markers within the area of the pattern are not permitted.

1. Run with speed to the far end of the arena past the end marker, and do a left rollback. Do not hesitate.
2. Run to the opposite end of the arena past the end marker, and do a right rollback. Do not hesitate.
3. Run past the center marker of the arena, do a sliding stop, and back straight to the center of the arena. Hesitate.
4. Complete four spins to the right.
5. Complete four and one-quarter spins to the left. Hesitate.
6. Beginning on the right lead, complete three circles to the right, the first two circles large and fast, the third circle small and slow. At the center of the arena, change leads.
7. Complete three circles to the left, the first two circles large and fast, the third circle small and slow. At the center of the arena, change leads.
8. Begin a large fast circle to the right. Do not close this circle, but run straight down the side of the arena past the center marker, and do a sliding stop approximately 20 feet from the wall or fence. Hesitate, to demonstrate the completion of the pattern.

The bridle may be dropped at the judge's discretion.

## Reining Pattern #8

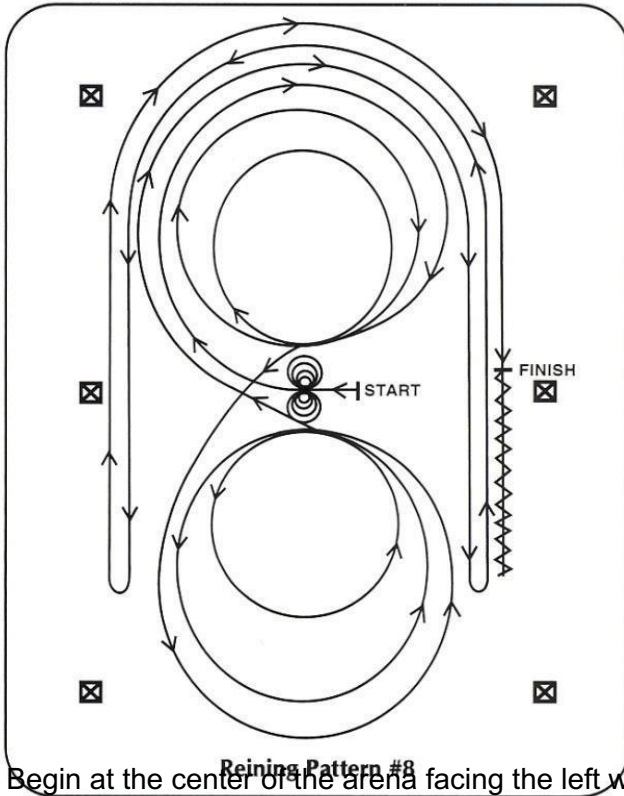

Begin at the center of the arena facing the left wall or fence.

1. Complete four spins to the left.
2. Complete four spins to the right. Hesitate.
3. Beginning on the right lead, complete three circles to the right: the first circle large and fast; the second circle small and slow; the third circle large and fast. Change leads at the center of the arena.
4. Complete three circles to the left: the first circle large and fast; the second circle small and slow; the third circle large and fast. Change leads at the center of the arena.
5. Begin a large fast circle to the right, but do not close this circle. Run straight down the right side of the arena past the center marker, and do a left rollback at least 20 feet from the wall or fence – no hesitation.
6. Continue back around the previous circle to the left, but do not close this circle. Run down the left side of the arena past the center marker, and do a right rollback at least 20 feet from the wall or fence – no hesitation.
7. Continue back around the previous circle to the right, but do not close this circle. Run down the right side of the arena past the center marker, and do a sliding stop at least 20 feet from the wall or fence. Back up at least 10 feet. Hesitate to demonstrate completion of the pattern.

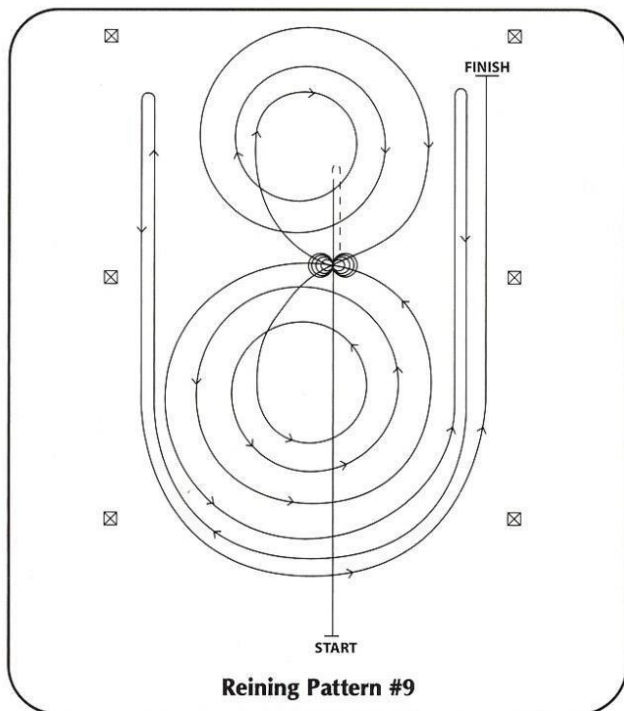

1. Run past the center marker, and do a sliding stop. Back up to the center of the arena or at least 10 feet. Hesitate.
2. Complete four spins to the right.
3. Complete four and one-quarter spins to the left, so that the horse is facing the left wall or fence. Hesitate.
4. Beginning on the left lead, complete three circles to the left: the first circle small and slow; the next two circles large and fast. Change leads at the center of the arena.
5. Complete three circles to the right: the first circle small and slow; the next two circles large and fast. Change leads at the center of the arena.
6. Begin a large, fast circle to the left, but do not close this circle. Run up the right side of the arena past the center marker, and do a right rollback at least 20 feet from the wall or fence  
– no hesitation.
7. Continue back around the previous circle to the right, but do not close this circle. Run up the left side of the arena past the center marker, and do a left rollback at least 20 feet from the wall or fence – no hesitation.
8. Continue back around previous circle to the left, but do not close this circle. Run up right side of the arena past the center marker, and do a sliding stop at least 20 feet from the wall or fence. Hesitate to demonstrate completion of the pattern.

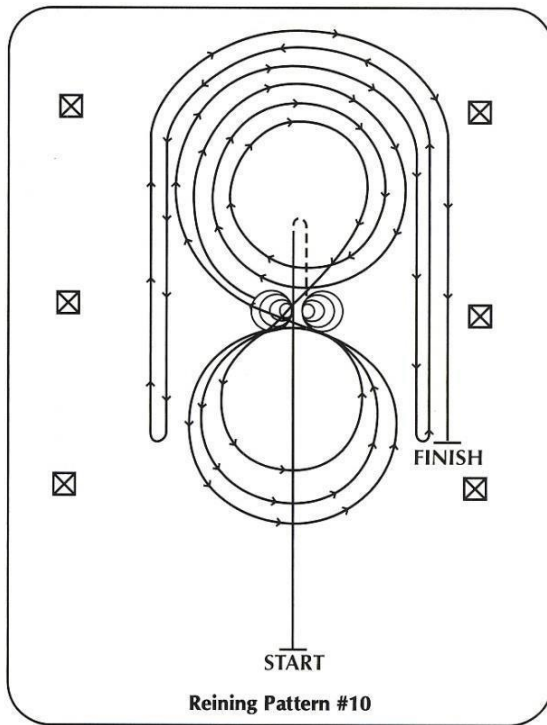

1. Run past the center marker, and do a sliding stop. Back up to the center of the arena or at least 10 feet.
2. Complete four spins to the right.
3. Complete four and one-quarter spins to the left, so that the horse is facing the left wall or fence. Hesitate.
4. Beginning on the right lead, complete three circles to the right: the first two circles large and fast, the third circle small and slow. Change leads at the center of the arena.
5. Complete three circles to the left: the first circle small and slow, and the next two circles large and fast. Change leads at the center of the arena.
6. Begin a large fast circle to the right, but do not close this circle. Run down the right side of the arena past the center marker, and do a left rollback at least 20 feet from the wall or fence – no hesitation.
7. Continue back around the previous circle to the left, but do not close this circle. Run down the left side of the arena past the center marker, and do a right rollback at least 20 feet from the wall or fence – no hesitation.
8. Continue back around the previous circle to the right, but do not close this circle. Run down the right side of the arena past the center marker, and do a sliding stop at least 20 feet from the wall or fence. Hesitate, to demonstrate a completion of pattern.

The bridle may be dropped at the judge's discretion.

## Freestyle Reining

Freestyle Reining not only provides an opportunity to use Reining maneuvers creatively, but also to expand them to music by means of choreography. Riders are encouraged to use musical scores which permit them to show the athletic ability of the horse in a crowd appealing way. This class will be judged as the Reining class regarding penalties and credits.

1. This class will not count for High Point Stock Horseman awards.
2. For this class only – exhibitors are allowed to use two hands (as well as one or no hands) and any bit approved by the Texas 4-H Horse Show Rules, including snaffle bits and bosals, regardless of horse age.
3. Required maneuvers: a minimum of 4 consecutive spins to the right; a minimum of 4 consecutive spins to the left; a minimum of 3 stops; a minimum of 1 lead change at the lope from right to left; a minimum of 1 lead change at the lope from left to right
4. Failure to perform all the required maneuvers or failure to complete the performance within the time limit will result in an off pattern (OP).
5. Time Limit: a maximum of 4 minutes including any introductions. The time limit will begin when the horse enters the arena and will end when the music stops.
6. Additional maneuvers such as rollbacks, backups, speed variations and non-classical reining maneuvers such as half pass and side pass are appropriate in Freestyle and shall be given appropriate credit. Additional repetitions of required maneuvers are appropriate, but will only add or subtract from the existing scores already given for the required maneuvers, not as additional scores.
7. Costumes: Permitted but not required. Emphasis is placed on performing the reining maneuvers to music.
8. Props: Permitted but at no time may hinder the judge's view of the horse. The use of props will not add to the score. Props not permitted: pyrotechnics, firearms or weapons (real or toy), additional live animals such as, but not limited to dogs, other horses etc.
9. Show management will reserve the right to rule on music or dress which may be inappropriate or offensive to the spirit and nature of the show. Music must be provided to and approved by the class superintendent a minimum of 1 hour prior to the start of the class.
10. Riders may **NOT** ride bareback, saddles are required.

# Stock Horse Trail

This class, as the name implies, tests the horse's ability to cope with many situations encountered in everyday work. The horse is ridden through a pattern of obstacles, which should nearly approximate those encountered during the course of everyday work. The horse is judged on the cleanliness, neatness, and promptness with which the obstacles are negotiated, ability to negotiate obstacles correctly, and attitude and mannerisms exhibited by the horse while negotiating the course. Emphasis on judging should be on identifying the well-broke, responsive, well-mannered horse which can correctly negotiate the course. The object is not to trap a horse or eliminate it by making an obstacle too difficult. All courses and obstacles are to be constructed with safety in mind, so as to eliminate any accidents.

## Trail Class Obstacle Requirements

1. Course will include no less than six and no more than nine obstacles. It is mandatory that the horse be asked to walk, trot, and lope during the course.

Walk – can be part of obstacle score and scored with approaching obstacle.

Trot – at least 35 ft. and scored with approaching obstacle.

Lope - at least 50 ft. and scored with approaching obstacle and be lead specific.

2. Care must be exercised to avoid setting up of any obstacles that may be hazardous to the horse or rider.
3. No extra verbal instructions may be given to the exhibitors by management or a judge that is not written in course description.
4. Judges must walk the course. Judges may remove or change any obstacle they deem unsafe, non-negotiable, or unnecessarily difficult. If, at any time, a trail obstacle becomes unsafe during a class, it shall be repaired or removed from the course. If it cannot be repaired and horses have completed the course, the score for that obstacle shall be deducted from all previous works for that class.
5. The actual trail course cannot be made available to exhibitors prior to the day of competition, but must be posted at least one hour prior to competition.
6. The course may be walked on foot by the exhibitor but no horse/rider exhibitors are allowed on the actual course after it has been set until their trail run begins.
7. Course must be designed using the mandatory obstacles and maneuvers plus optional obstacles. Combining of two or more of any obstacles is acceptable.
8. Prohibited obstacles: Tarps, water obstacles with slick bottoms, PVC pipe used as a jump or walk over, tires, rocking or moving bridges, logs or poles elevated in a manner that permits such to roll in a dangerous manner. Animals live or stuffed (Exception: Animals which would normally be encountered in a ranch setting and which are not used in an attempt to "spook" a horse could be used.).
9. Mandatory obstacles or maneuvers:

- a. Ride over obstacles on the ground – usually logs or poles. It is recommended that all three gaits (walk, trot, lope) be used; however, only two gaits are required. Walk-Overs – Walk over no more than five logs or poles. The space between logs for walk-overs should be 20-24” apart and no more than 10” high. These can also be in a straight line, curved, zigzagged, or raised.
  - b. Trot–Overs – Trot over no more than five logs or poles. The space between trot-overs should be 36-42”. Poles may be elevated a maximum of 10”. These can also be in a straight line, curved, zigzagged, or raised.
  - c. Lope-Overs – Lope over no more than five poles. The space between lope-overs should be 6’ to 7’. Poles may be elevated a maximum of 10“. These can also be in a straight line, curved, zigzagged, or raised.
  - d. Opening, passing through, and closing gate. A gate should be used that will not endanger horse or rider and requires minimum side passing.
  - e. Ride over wooden bridge. (Suggested minimum width shall be 36” wide and at least six feet long). Bridge should be sturdy, safe, and negotiated at a walk only. Heavy plywood lying flat on the ground is an acceptable simulation of a bridge.
  - f. Backing obstacles – Backing obstacles are to be spaced a minimum of 28” spacing. If elevated, 30” spacing is required. Back through and around at least three markers. Back through L, V, U, straight or similar shaped course. May be elevated no more than 24”.
  - g. Side-pass obstacle – Any object which is safe and of any length may be used to demonstrate responsiveness of the horse to leg signals. Raised side-pass obstacles should not exceed 12”.
10. Optional obstacles: Following is a list of optional obstacles from which selections can be made, but not limited to:
- a. Jump - An obstacle whose center height is not less than 14” high or more than 24” high. Holding the saddle horn is permissible for this obstacle
  - b. Carry object from one part of the arena to another,
  - c. Remove and replace materials from mailbox,
  - d. Trot through cones – spacing to be minimum of 6’,
  - e. Cross natural ditches or up embankments,
  - f. Step in and out of obstacle,
  - g. Put on slicker or coat,
  - h. Pick-up feet,
  - i. Walk through brush,

- j. Ground tie, Lead at the trot.

## Scoring Stock Horse Trail

Stock Horse Trail will be scored from 0 to infinity with 70 denoting average. The individual maneuvers are scored in  $\frac{1}{2}$  point increments from a low of  $-1\frac{1}{2}$  to a high of  $+1\frac{1}{2}$ , with a score of 0 denoting a maneuver that is correct with no degree of difficulty.

### Penalties:

1. One point
  - a. Each hit, bite, or stepping on a log, cone, plant or any component of the obstacle
  - b. Incorrect or break of gait at walk or trot for two strides or less
  - c. Both front or hind feet in a single-stride slot or space at a walk or trot
  - d. Skipping over or failing to step into required space
  - e. Split pole in lope-over
  - f. Incorrect number of strides, if specified
  - g. One step on dismount/remount or ground tie except shifting to balance
  - h. Over-bridled (per maneuver)
2. 3 Points
  - a. Wrong lead or break of gait at the lope (except when correcting an incorrect lead)
  - b. Draped reins
  - c. Break of gait at walk or trot for more than two strides
  - d. Two to three steps on dismount/remount or ground tie
3. 5 Points
  - a. Spurring in front of cinch
  - b. Four or more steps on dismount or ground tie
  - c. Blatant disobedience
  - d. Use of either hand to instill fear or praise
  - e. Use of two hands (per maneuver)
  - f. More than one finger between split reins or any fingers between romal reins (per maneuver)
  - g. Knocking over, stepping out of, or falling off of an obstacle
  - h. Dropping an object required to be carried
  - i. 1<sup>st</sup> or 2<sup>nd</sup> cumulative refusal
  - j. Letting go of gate
4. Off-Pattern (OP) (cannot place above others who complete pattern correctly)
  - a. Breaking pattern (including never performing designated gait or lead)
  - b. Repeated disobedience
  - c. Leaving working area before pattern is complete
5. Disqualification (DQ)
  - a. Lameness
  - b. Abuse
  - c. Illegal equipment
  - d. Disrespect or misconduct
  - e. Fall of horse or rider

Trail Credits:

Credit is given to horses negotiating the obstacles with style and some degree of speed, providing correctness is not sacrificed. Horse should receive credit for showing attentiveness to obstacles and capability of picking their own way through the course when the obstacles warrant it, and willingly responding to the rider's cues on more difficult obstacles. Quality of movement and cadence should be considered part of the maneuver score for the obstacle.

**Horses should not be ridden over tarps or plastic of any kind.**

**Exhibitors will not be asked to drag or pull any object.**

## Stock Horse Pleasure

This class serves to measure the ability of the horse to be functional and a pleasure to ride while being used as a means of conveyance from one task to another. This horse should be well-broke, relaxed, quiet, soft, and cadenced at all gaits. The horse should be ridden on a relatively loose rein with light contact and without requiring undue restraint. Excessively long, floppy reins will not be given extra credit. The horse should be responsive to the rider and make all required transitions smoothly, timely, and correctly. The horse should be soft in the bridle and yield to contact.

Horses shall be shown individually at the walk, trot, and lope in both directions. The walk, trot, and lope will be extended in one direction only. Markers set up in the arena will designate gait changes. The following Patterns may be started in either the right or left direction:

1. PATTERN I
  - Extended Walk
  - Trot
  - Extended Trot
  - Lope
  - Stop and Reverse
  - Ordinary Walk
  - Lope
  - Extended Lope
  - Trot
  - Stop and Back
2. PATTERN II
  - Ordinary Walk
  - Lope
  - Extended Lope
  - Trot
  - Stop and Reverse
  - Extended Walk
  - Trot
  - Extended Trot
  - Lope
  - Stop and Back
3. PATTERN III
  - Ordinary Walk
  - Lope
  - Extended Trot
  - Trot
  - Stop and Reverse
  - Trot
  - Lope
  - Extended Lope
  - Extended Walk
  - Stop and Back
4. PATTERN IV
  - Trot - 90 feet
  - Extended Walk
  - Lope
  - Extended Trot
  - Stop and Reverse
  - Lope
  - Extended Lope
  - Ordinary Walk
  - Trot
  - Stop and Back
5. PATTERN V
  - Lope
  - Extended Lope
  - Ordinary Walk
  - Trot
  - Stop and Reverse
  - Extended Trot
  - Trot
  - Extended Walk
  - Lope
  - Stop and Back

## Description of Ideal Pleasure Gaits

The ideal pleasure horse will have a level head carriage at each gait – neither too high nor too low.

**Walk** – The walk should be straight, square, flat footed, relaxed, and should move out freely with horse looking ahead.

**Extended Walk** – The extended walk should be straight, square, flat footed, relaxed, and should move out freely with horse looking ahead, It should show more length of stride than the ordinary walk.

**Trot** – This gait should be a square two-beat diagonal trot. The trot should be steady, soft, and slow enough for riding long distances. Trots which are too fast, rough and hard to sit should be penalized. Excessively slow and uncadenced trots should also be penalized.

**Extended Trot** – The extended trot should show a definite lengthening of stride from the regular trot with the same cadence, which will cause an increase in speed. This trot should be level, flat, and steady with the appearance that the horse could hold this gait for an extended distance. The method riders chose to ride the extended trot is optional. It is acceptable to either post at the trot, sit, or stand in the stirrups, while holding the saddle horn, at the extended trot only.

**Lope** – This gait should be a three-beat gait that is collected, cadenced, straight and steady, and is comfortable to ride.

**Stop** (from both lope and trot) – The horse should be in the correct stopping position – both hocks engaged and stopping on the hindquarters.

**Reverse** – A horse should turn briskly and flat with front feet on the ground and holding an inside rear pivot foot.

**Extended Lope** – This gait should be an obvious lengthening of stride from the previous lope, be at the same cadence and cause an increase in speed. The gait needs to be steady, quiet, and holding the increased speed while being under complete control.

## Scoring the Stock Horse Pleasure

Judging should be based on quality of movement, mannerisms, disposition, and responsiveness to the rider. Part of the evaluation of this class is on smoothness of transitions. All transitions should be smooth with willingness and responsiveness to the rider's cues. Note that the rules allow for a horse to be taken back (collected) a bit from the extended trot as the horse moves into the lope. The transition from the extended lope down to the trot is very difficult to achieve; however, a good stock horse should be able to make this transition smoothly and easily, with calmness and a good attitude.

Stock Horse Pleasure will be scored from 0 to infinity with 70 denoting average. The individual maneuvers are scored in ½ point increments from a low of -1½ to a high of + 1½, with a score of 0 denoting a maneuver that is correct with no degree of difficulty.

Penalties:

1. One point penalties
  - a. Over-bridled (per maneuver)
  - b. Out of frame

- c. Too slow
- d. Gaping mouth
- e. Break of gait at walk or trot for two strides or less
- 2. 3 point penalties
  - a. Wrong lead
  - b. Draped reins
  - c. Break of gait at lope
  - d. Break of gait at walk or trot for more than two strides
- 3. 5 point penalties
  - a. Spurring in front of cinch
  - b. Blatant disobedience
  - c. Use of either hand to instill fear or praise
  - d. Use of two hands (per maneuver)
  - e. More than one finger between split reins or any fingers between romal reins (per maneuver)
- 4. Off Pattern (OP) cannot place above others who complete pattern correctly
  - a. Breaking pattern (including never performing designated gait or lead)
  - b. Repeated disobedience
  - c. Leaving working area before pattern is complete
- 5. Disqualification (DQ)
  - a. Lameness
  - b. Abuse
  - c. Illegal equipment
  - d. Disrespect or misconduct
  - e. Fall of horse or rider

## Stock Horse Horsemanship

**Exhibitors cannot show the same horse in both the Western Horsemanship and Stock Horse Horsemanship at the State 4-H Show.**

1. The class will be judged on the horsemanship and overall riding ability of the rider. Recognition will be given to the exhibitor's ability to ride a horse functionally, with correct position, using various aids to cause the horse to perform required basic stock horse maneuvers. The performance of the horse is not to be judged more important than the riding ability of the exhibitor. Scores on individual works will be based on the rider's skills during execution of the pattern. **The emphasis of this class will be to reward the stock horse riders who have the best horsemanship skills, while completing stock horse- type maneuvers.**
2. **Exhibitors CANNOT show the same horse in both the Western Horsemanship and Stock Horse Horsemanship.**
3. Horses to be shown in plain, clean and functional, western tack and conservative western attire. **No chaps, or chinks of any kind will be allowed in this class.** A conservative scarf around the neck is allowed but should not detract from the overall conservative appearance of the exhibitor. Tack should be traditional and conservative in appearance and should not display extraordinary silver or other decorations other than normal buckles and connectors. Judge may fault riders who are in violation of the intent of this rule. No banded or braided manes, or hoof black will be allowed.
4. Rules concerning legal reins, bits and other tack are same as other western stock

horse classes. Protective boots or leg wraps (conservative colors) on the horse are allowed.

## General - Position

**Arms and hands.** Arms and hands should be held in an easy, relaxed manner. Upper arms are held in a straight line with the body, with the arm holding the reins bent at the elbow. Only one hand is used for reining, and hands shall not be changed on the reins. Free hand should not touch the saddle at any time. The reining hand is to be around the reins with one finger permitted between split reins. Reins are to be carried immediately above and slightly in front of the saddle horn. Reins should be held so that **light contact** is maintained with the horse's mouth. Riders with soft, supple hands which are able to show their horse with minimal movement of the reins should be rewarded. Reins with a romal are allowed, but reins must be held in one hand, with hand completely around the reins, in a fist position, with the thumb up. When using a romal, no fingers between the reins. The non-rein hand must be on the romal (tail) and cannot be changed during the performance. If the non-rein hand touches the reins at any time during the performance, it should result in a disqualification.

**Basic position.** The rider should sit in a comfortable, balanced, relaxed, and flexible manner. The lower leg should hang straight down from the knee to the stirrups with a slight bend in the knee, depending on the type of saddle. Stirrups should be just long enough for the heel to be in a direct line under the shoulders and hips, with the heels lower than the toes. This allows flexion in the ankle joint which provides for a more balanced ride, and allows rider to stay in rhythm with the horse. The feet should be placed in the stirrups with the boot heel touching the stirrup or slightly less deep. Riding with the weight on the toes will be penalized. The toes should be turned only slightly out, with the ankles flexed in a comfortable position. The lower legs and feet should be kept close to the horse's body, but not in constant contact except when applying aids. Application of leg aids should be barely perceptible by the judge. Upper body should be upright, but relaxed and not rigid. Shoulders should be square and head and eyes should be up and looking ahead.

**Position in Motion.** The rider shall sit the trot and not post. The rider should be close to the saddle at a lope. If asked for an extended trot, rider may post, stand, or sit. Exaggerated shifting of the rider's weight is not desirable and will be penalized in judging. Rider should at all times, be in rhythm with the movement of the horse so as to present a smooth, efficient and functional overall appearance and to always be in position to aid the horse during required maneuvers.

## Class Routine

The judge will ask each rider to work individually. Individual works will be a combination of stock horse maneuvers that the judge feels are necessary to determine the horsemanship ability of the rider. **Scoring for this class will be based on the combination of basic position of the rider and the ability to effectively communicate with the horse to execute a smooth, efficient and correct pattern.**

The pattern will include maneuvers from the following list, or any maneuvers that the judge feels are appropriate to test the horseman's ability:

- a. straight walk, trot, and lope, and/or circles in either direction
- b. stop
- c. back straight, in an "L", or in a circle

- d. 360-degree (or more) spin
- e. pivot, both ways
- f. turns of 90, 180 or 270 degrees
- g. rollbacks
- h. lope circles of varying size and speed
- i. pick up leads from standstill, walk, or trot
- j. simple or flying lead changes on a straight away or in a circle
- k. side pass
- l. counter canter
- m. two track
- n. drop and pick up stirrups

The pattern should be posted at least 1 hour before the class begins.

The judge will use these individual work scores to determine the top riders who may be asked for additional individual work or work on the rail. Selected riders (or all riders if the class is small) may be asked to work on the rail to determine final placing (rail work is optional). If held, rail work will include walk, jog, and lope in one or both directions of the ring at the discretion of the judge.

1. Exhibitors will be scored from 0 to infinity with 70 denoting an average performance. Patterns will be divided into 6 to 10 maneuvers, as specified by the judge, and each maneuver will be scored from +3 to -3 with ½ point increments acceptable that will be added or subtracted from 70. Maneuver scores should be determined independent of penalties, and should reflect equal consideration of both performance of the exhibitor's pattern and the horsemanship form and effectiveness of the exhibitor to result in the following scores: +3 excellent, +2 Very Good, +1 Good, 0 Average or Correct, -1 Poor, -2 Very Poor, -3 Extremely Poor. Exhibitors overall horsemanship form and effectiveness should also be scored from 0 to 5 with 0 to 2 being Average, 3 Good, 4 Very Good, 5 Excellent. Exhibitors may also be judged on the rail, and their pattern score and/or ranking may be adjusted as appropriate.
2. Penalties:
  - a. 1 Point
    - i. Ticking or hitting obstacle such as cone, log or plant
  - b. 3 Points
    - i. Break of gait at walk or jog/trot up to two strides
    - ii. Severely disturbing obstacle
  - c. 5 Points
    - i. Not performing the specific gait or not stopping when called for in the pattern within 10 feet of the designated area
    - ii. Incorrect lead or break of gait (except when correcting an incorrect lead) at the lope
    - iii. Break of gait at walk, jog or trot for more than two strides
  - d. 10 Points
    - i. Loss of rein
    - ii. Holding saddle with either hand (exception: riders may hold saddle during the extended trot)
    - iii. Cueing with the end of the romal
    - iv. Blatant disobedience including kicking, pawing, bucking and rearing
    - v. Spurring in front of cinch
  - e. Disqualifications

- i. Lameness
  - ii. Failure to follow class dress code
  - iii. Failure to display correct number
  - iv. Abuse of horse or schooling
  - v. Fall by horse or rider
  - vi. Illegal equipment or illegal use of hands on reins
  - vii. Use of prohibited equipment, such as silver on tack
- f. Off pattern, including: wrong side of cone or marker; never performing designated gait or lead; over or under turning more than ¼ turn; must place below exhibitors who complete pattern correctly.

## Stock Horse Showmanship

The Stock Horse Showmanship class is judged on the exhibitor's ability to fit and train a horse for a show or sale. Emphasis will be on proper fitting of the horse and the ability to present a well-groomed, well-trained horse to the judge through a series of practical and basic maneuvers from the ground. The class should always be judged with this in mind, giving credit to the exhibitor who can correctly perform each maneuver of the total pattern or run. Judges should refrain from conducting the class routine in any manner that attempts to trick, confuse, or mislead exhibitors. In Stock Horse Showmanship, conformation of the horse is not judged. **Exhibitors CANNOT show the same horse in both the Western Showmanship and Stock Horse Showmansjp.**

**Attire.** Exhibitors should be neat, clean, and well-groomed. Required attire is the same as that required for Stock Horse Horsemanship. Conservative scarves around the neck are acceptable. Hats should be clean and well-shaped and cowboy boots should be clean. Chaps and spurs are NOT permitted in showmanship.

**Equipment.** Use a clean halter that is adjusted to fit the horse. The halter should fit well on the horse's head, to maximize response to subtle halter cues. Plain leather halters, flat nylon halters or rope halters are acceptable and should be clean, neat and adjusted and well-fitted to the individual horse. Silver on halters is not allowed other than on normal buckles and hardware. Judges may penalize contestants who do not conform. Lead straps are often attached to a chain and snap. The lead strap may be snapped below the jaw in the center ring of the halter, or the chain can be run under the horse's chin and snapped to the upper or lower halter ring on the right side of the horse's head.

### Horse Fitting and Grooming

1. The horse should be clean and well-groomed. Manner of fitting for mane and tail may vary according to recognized practices for a stock-type horse. Emphasis should be on proper fitting and grooming acceptable for high-end stock horse sales. Hair coat should be clean, shiny and should show evidence of frequent grooming. Underweight or thin horses will be penalized. It is acceptable to trim bridle paths, ears, nose and fetlocks to make the horse more attractive, just as one might do for a horse sale. Horses' feet should be clean, neat and well-trimmed or shod. Hoof black should not be used.
2. A well-groomed horse that is clean, properly trimmed, and conditioned does have a justified advantage in showmanship at halter.

### Method of Showing

1. Walk, trot, turn, stop, back, and pose the horse as shown in the posted pattern or by

the judge's instructions.

2. The horse is always led from the left side. The exhibitor's right hand is held closest to the halter, with the distance being highly dependent upon the mannerisms of the horse, the size of both the horse and the exhibitor, and breed standards. The excess amount of lead is folded or loosely coiled in the left hand and held about waist high. Never wrap the excess lead around the hand or make a coil so small that a sudden jerk could cause the lead to wrap around the hand.

3. At both the walk and the trot, the exhibitor's shoulder should be about even with the horse's throatlatch. In this position, the horse is beside the exhibitor, allowing the judge a clear view of the horse's travel. Movement at both gaits should be brisk and sharp, as opposed to slow and dull. Speed of travel is somewhat related to straightness of travel, and the slower a horse moves, the greater chance for deviation from a straight line of movement.

4. When leading to or from a judge or ringmaster, stops and turns are very important. The exhibitor should always allow plenty of space between the horse and the judge. Stops should be executed squarely and without hesitation, as the stop is an important maneuver preceding a correct turn or reverse of direction.

5. Turns of more than 90 degrees should always be executed to the right. Pushing the horse away, rather than pulling the horse around, will allow more distance between the horse's and the exhibitor's feet. In addition, turning to the right allows the horse to use the right hind foot as a pivot point. The horse can then cross the left front foot over the right front to execute a very uniform and smooth turn. This results in the horse remaining in essentially the same tracks after the turn is completed and provides the judge a good view as the horse is walked or trotted away.

6. Immediately following a turn or reverse of direction, the exhibitor should look back to make sure the horse is lined up with the judge. Class routines may require walking or trotting back into the lineup of horses. The exhibitor should lead all the way through the line, stop, reverse, and then lead into the line to set up. If asked to change positions in the line, back the horse out of the line, and approach the new position from behind.

7. Pose or set up the horse with its feet set according to its type or breed. Stock horse breeds stand square. Move the horse's feet by pushing or pulling on the lead strap as necessary with the right hand. Touching the horse's body with a hand or foot to change the horse's position is penalized.

8. Once set up, the horse should be presented in such a way as to not distract the judge's attention from the horse. The exhibitor stands on the opposite side of the horse when the judge is toward the front and on the same side as the judge when the judge is toward the rear of the horse. This method of presentation is preferred by most judges for youth exhibitors.

9. For safety reasons, at no time should an exhibitor stop and stand directly in front of the horse.

10. The primary objective is to show the horse. Exhibitors should stand where they can see the judge and the judge can see them, but without obstructing the judge's view of the horse. The basic position of the exhibitor should allow constant observation of the horse's position and also permit observation of the judge.

11. Staring at the judge keeps an exhibitor from continually observing the horse and keeping the horse set properly. Exhibitors should maintain eye contact with the horse. It is acceptable to

glance at the judge from time to time, but an exhibitor should NOT do this continuously.

12. Exhibitors should keep their proper position in line and allow reasonable space (at least 5 feet) between horses on either side. Keep horses from making contact with a competitor or encroaching on space rightfully belonging to another exhibitor.

13. Additional tests, such as walking or trotting over logs, leading horses through a gate, moving around markers such as cones or other suitable obstacles, ground tying or any other maneuver which the judge feels is a fair test for determining the level of training and ground handling ability of a stock horse, may be included in the pattern.

14. When ground tying, it is acceptable to either drape the leadline over the horse's neck, or drop the leadline to the ground.

#### Scoring:

Exhibitors will be scored from 0 to infinity with 70 denoting an average performance. Patterns will be divided into 6 to 10 maneuvers, as specified by the judge, and each maneuver will be scored from +3 to -3 with ½ point increments acceptable that will be added or subtracted from 70. Maneuver scores should be determined independent of penalties, and should reflect equal consideration of both performance of the exhibitor's pattern and form and effectiveness of the exhibitor to result in the following scores: +3 excellent, +2 Very Good, +1 Good, 0 Average or Correct, -1 Poor, -2 Very Poor, -3 Extremely Poor. Fitting and grooming of the horse should also be scored from 0 to 5 with 0 to 2 being Average, 3 Good, 4 Very Good, 5 Excellent.

#### Penalties:

- a. 1 Point
  - i. Ticking or hitting an obstacle including cones, logs and plants
- b. 3 Point
  - i. Break of gait at the walk or trot for 2 to 3 strides
  - ii. 2 to 3 steps during a ground-tie
  - iii. Severely disturbing obstacle
- c. 5 Point
  - i. 4 or more steps during a ground-tie
  - ii. Not performing the specified gait or not stopping within 10 ft. of the designated area
  - iii. Over or under turning up to ¼ turn
  - iv. Letting go of or dropping gate
  - v. Break of gait at the walk or trot for more than 2 strides
- d. 10 Point
  - i. Exhibitor is severely and continuously out of position during inspection
  - ii. Excessive touching the horse or kicking or pointing at the horse's feet during set up
  - iii. Standing directly in front of the horse
  - iv. Complete loss of lead shank, unless executing ground tie maneuver
  - v. Severe disobedience including rearing or pawing; horse continually circling exhibitor
- e. Disqualification
  - i. Loss of control of horse that endangers exhibitor, other horses or judge
  - ii. Failure to display correct number

- iii. Failure to follow class dress code
  - iv. Willful abuse
  - v. Excessive schooling or training; use of artificial aids
  - vi. Illegal equipment
  - vii. Use of prohibited equipment, such as silver on halter
- f. Off pattern, including: wrong side of cone or marker; never performing designated gait; over or under turning more than ¼ turn; must place below exhibitors who complete pattern correctly

## Drill Division

This division contains three separate classes: drill, precision, and quad riding teams. Teams (in total or in part) may participate in either the drill, precision or quad riding class or any combination thereof.

### Objectives

1. To teach boys and girls teamwork.
2. To provide opportunities to demonstrate democratic procedure and group action.
3. To teach horsemanship and horse safety to 4-H members.
4. To provide an organized and supervised activity for 4-H members with horses.

### Requirements

1. Youth must be enrolled in 4-H with a horse project and meet all 4-H membership requirements.
2. Horse ownership by the 4-H member is mandatory. See ownership rules.
3. Mounted teams must establish membership requirements with a specific program of teaching and practice. Youth must meet all requirements of the mounted team of which they are members.
4. **All riders on a team must be from the same or adjacent county.**

### Organization

1. Mounted teams may be formed from existing project groups, horse clubs, and/or other 4-H members with horse projects.
2. More than one team may come from a single county.
3. One adult leader will be selected as the team master. Assistants to the team master may be appointed.

4. The 4-H members may elect a team captain and other officers as needed.

## Drill Class

1. **The use of props by drill teams is prohibited at the District and State Shows. There will be no pyrotechnics or smoke of any kind.**
2. **No pre-recorded introductory commentary will be allowed prior to or during the drill competition. Each team will be introduced by the announcer prior to the performance.**
3. Each drill routine should be no longer than 10 minutes. Two points will be deducted from each judge's score card for each minute the drill routine exceeds the 10 minutes. At least 3 seconds of each minute over 10 minutes must be consumed before the penalty is assessed. The 10-minute allowance begins when the first horse enters the arena and ends when the last horse leaves the arena. Time consumed as a result of an accident or other unforeseen circumstances that require stopping the drill is NOT counted as part of the 10-minute time allowance.
4. Teams shall be composed of no fewer than **6** members and no more than 20 members. (Teams may have larger membership, but routines will be developed for these minimum and maximum numbers of members.)
5. Drills will be judged as a group, with credit given for Execution, Performance and Manners of horses, Content of Drill, Presentation, Degree of Difficulty, Horsemanship and general Impression.
6. Scoring and penalties will be congruent with Equestrian Drill Teams of Texas score sheets. Fall of horse or rider as a result of a collision will be penalized 100 points each occurrence. Fall of horse or rider NOT resulting from a collision will be penalized 25 points each occurrence.

## Drill Team Scoring

Drill teams will be scored using the Equestrian Drill Teams of Texas Score Sheet, with a maximum 1000 points possible.

Execution (350 points total)

Spacing (100)

Alignment (100)

Timing & Coordination (100)

Briskness (50)

Performance and Manners of Horses 50 points

Content of Drill (100 points total)

Originality (25)

Variety (25)

Attractiveness of Patterns (50)

Presentation (300 points total)

Spectacularity & Crowd Appeal (100)

Music (100)

Costumes (100)

Degree of Difficulty (100 points)

Horsemanship (50 points)

General impression (50 points)

## Precision Riding Teams

1. All precision riding teams will ride the same standard routine found in the State 4-H Horse Show Rules. See figure below. No time limits will be placed on this routine; however, the standard routine will be designed to be completed in less than 15 minutes. **Standard background music WILL NOT be provided for all teams. Music MUST BE an instrumental piece.**
2. **No pre-recorded introductory commentary will be allowed prior to the precision competition. Each team will be introduced by the announcer prior to the performance.**
3. The standard Western dress will be casual pants (blue jeans, denim, cotton, etc.; no dress pants are allowed) and a plain white shirt or blouse. The standard hunter dress will be breeches or jodhpurs, a hunter-type blouse or shirt, a hunter-type hat, and boots. Coats should not be worn.
4. No matching coats, vests, sweaters, etc., are allowed.
5. The following items may match, but matching items are not required.
  - a. Hats, ties, or neck scarves for riders.
  - b. Leg wraps, saddle blankets, bridles, and breast collars for horses.
6. The precision riding team shall be made up of an **even** number of riders, with a minimum of **6** riders and a maximum of 20 riders.

### Precision Riding Score Sheet

The whole group will be judged based on horsemanship ability (45), precision of execution of standardized routine (45), and team appearance (10).

### Precision Riding Pattern

1. Riders enter the arena in pairs at a trot. The riders trot down the middle of the arena. At the center of the arena, riders will split and two-track to the wall. Once on the wall they will continue down the side at a trot to the end of the arena.

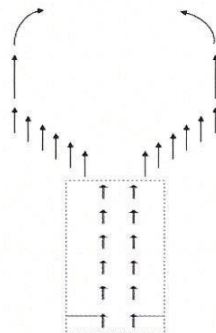

2. The riders will turn right or left in lines, pairing back up in the center and trotting

down the center of the arena. Once the group is in paired lines, centered in the middle of the arena, they will stop as a group.



- The riders will simultaneously make a pivot (270 degrees) away from the middle of the arena.

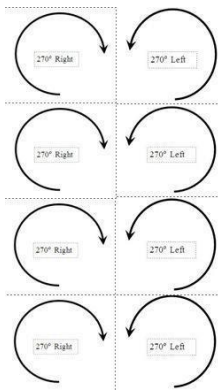

- The horses back four steps simultaneously.

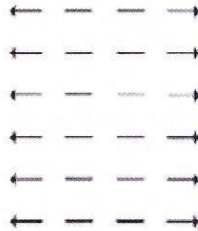

- At a trot, the two lines of riders ride forward, passing between each other, and continue to the rail. Upon reaching the rail, the riders turn left and form single-file lines on the rail.

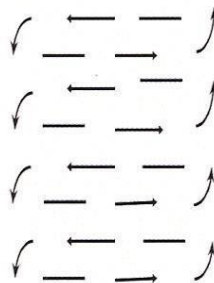

- Upon reaching the opposite ends of the arena, the riders will proceed at a lope into interlocking circles and complete two full circles

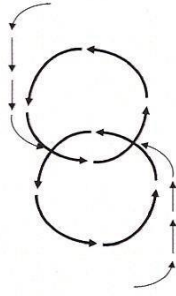

7. After completing the two interlocking circles, the riders break the interlocking circles, ride to the rail at a lope, turn to the left down the rail, at the end of the arena slow to a trot, cross the end of the arena, and trot to the opposite rail.

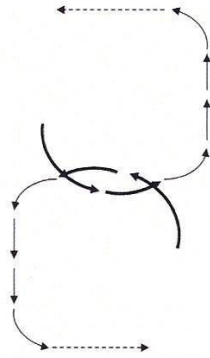

8. The lead rider, upon reaching the rail, slows to a walk, with each successive rider riding forward with his or her horse's head at the preceding rider's knee, forming a walking diagonal line down  $\frac{1}{2}$  the length of the arena.

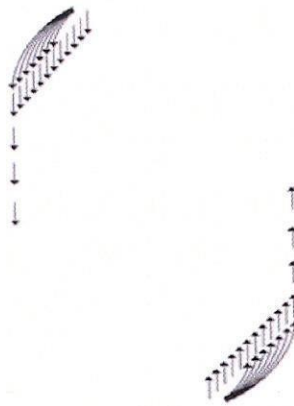

9. When the rider closest to center of the arena reaches center, the riders will turn in succession toward the middle of the arena, thus forming a straight line. Upon reaching the middle of the arena, the riders will line up in a close side by side line stop and hesitate.

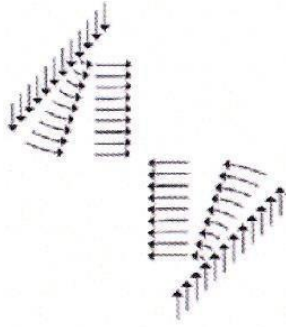

The riders execute one full turn (360 degrees).<sup>11</sup> After completing one full circle, the designated rider leads the team into a figure eight, starting at the left side of the arena, being sure to pass to the inside of the circle. The team completes two figure eights at a lope.

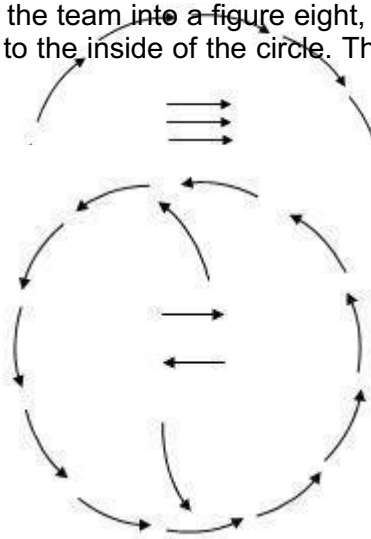

12. The lead rider, after completion of the second figure eight, rides to the rail, turns to the left, slows to a trot, and trots down the rail to the end of the arena.

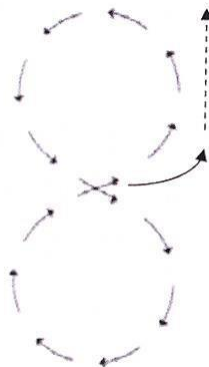

13. Upon reaching the end of the arena, the riders slow to a trot and form groups four abreast. The groups of four ride down the middle of the arena. When all the groups of four are formed, the groups should be head to tail alignment.

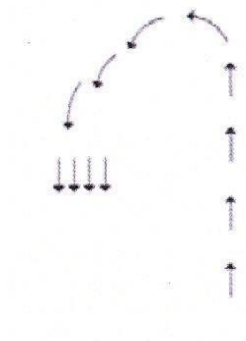

14. All riders trot through the center of the arena.

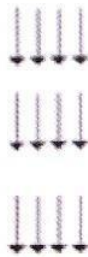

15. Upon reaching the end of the arena, all riders stop. Middle pair of riders file out of the arena in pairs at a walk.

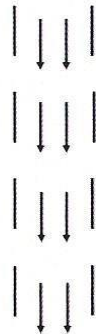

16. When the first section has exited, the remaining outside riders will side pass into the center and then exit at a walk.

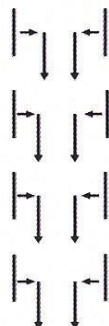

# Quad Drill

## **General Rules**

1. Each Drill Team member is required to comply with the Texas 4-H membership requirements.
2. Teams may contain 4 riders with 1 alternate per "Quad".
3. Each county will be allowed only 3 teams per county for the state 4-H Horse Show, with no re-occurring riders on Quad teams.
4. A horse will be allowed for competition in Drill and Quad. A hardship substitution will be allowed with a vet notice.
5. Commands executed during the drill must be made by a drill team member performing in the drill.
6. Commands may be executed using the following methods: voice, hand gestures, or whistle. Use of whistles is encouraged. Excessive use of whistles will be scored lower. Teams without whistles will be judged as a higher level difficulty.
7. All drills can begin and end on an open gate arena.
8. Costumes and Music should reflect theme and be 4-H appropriate. Costumes will not be judged as strongly as Horsemanship.
9. Quad Drills may contain the following gaits: walk, trot, lope, or canter.
10. Teams are responsible for their own music, music will NOT be provided.
11. Use of any markers or props set either in or around the arena is prohibited.
12. A mandatory coaches/team adult representative meeting will be scheduled prior to the class at the State 4-H Horse Show.
13. A time-out may be allowed by judges in case of an accident or fall.

## **Class Routine**

1. Riders may ride Western or English style. However, all four riders must ride the same style.
2. Drill can begin with riders entering the arena and lining up where their drill will begin or they can begin with an open gate.
3. The music begins when the drill lead acknowledges the judge by a loud whistle.
4. Drill length should be a minimum of 4 minutes and a maximum of 6 minutes.
5. Drills may contain any number of maneuvers; however, a quad drill must include at least three of the following six maneuvers:
  - Pinwheel
  - Thread the Needle
  - Circle
  - Dizzy Serpentine
  - Whip
  - Wave

All maneuvers listed can be found in "101 Drill Team Exercises for Horse and Rider" by Debbie Sams

## **Scoring**

Quad teams will be scored using the Equestrian Drill Teams of Texas Score Sheet, with a maximum 500 points possible.

Execution (Spacing, Alignment, Timing & Coordination, Briskness) 100 points  
Performance and Manners of Horses 20 points  
Content of Drill (Originality, Variety, Attractiveness of Patterns) 70 points  
Presentation (Spectacularity & Crowd Appeal, Music, Costumes) 60 points  
Degree of Difficulty 100 points  
Horsemanship 100 points  
General Impression 50 points

### ***Equipment***

1. The guidelines for western style follow the standards described under 4-H Speed event rules listed in the Texas 4-H Horse Program Rule Book, with the following exception: Snaffle bits, bosals and hackamores can be used on a horse of any age. Tie downs are allowed in western style riding.
2. Use of bats, whips, crops in western are not allowed.
3. The guidelines for English style follow the standards described under English Division in the Texas 4-H Horse Program Rule Book.

### ***Definitions***

Drill Team - A group of horse and riders performing a specific class. Such as Freestyle, Freestyle 5 riders and under, Quad or Compulsory.

Drill Master - The leader responsible for the team. The drill master does not ride with the team.

Drill leader/leads - Youth performing in the drill who execute commands during the drill to other team members.

Alignment - Vertical and horizontal alignment for both maneuvers and transitions.

Transitions - The action taken between maneuvers.

Spacing - Uniform distance which may be varied in different maneuvers or transitions. Spacing at any given time should be consistent.

Variety - Drill variety includes movements; i.e., single file, pairs, fours etc. variety of speed, and variety of ways the drill is performed.

Coordination and timing - The manner in which the members work as a team to perform their drill. Includes music coordination with drill movement.

Legal Flag Holder - A flag holder that attaches to the stirrup or saddle (not the rider) and does not impede the rider. It shall allow the flag to stay firmly in place and be safe for the rider.

Horsemanship/Equitation - Horsemanship/Equitation will be stressed as adapted for drill purposes. Faults listed under rules for Western Horsemanship and English Equitation in the Minnesota 4-H Horse Program Rule Book are considered during a drill performance but considerations are in place for it is recognized that this is a drill and therefore leniency is given accordingly.

Performance of horses - Manners, way of going and suitability of the horse for the drill performed.

Briskness - Precision, alignment, spacing and coordination of horses and riders executing maneuvers with excitement and energy. A clean performance with a positive attitude from both horse and rider.

Degree of Difficulty - This defines how spectacular a maneuver is performed. Speed is noted because a faster tempo; gait raises the difficulty of performing a given maneuver. Precision should not be sacrificed for speed.

## Texas Equine Liability Law

The Texas Legislature passed a liability law, effective September 1, 1995. The law defines terms associated with equine activities and the people involved and includes a warning. It also requires that a sign stating the warning be posted in a clearly visible location where equine activities take place. Post this sign at all locations where 4-H riding practices and competitive events are to be held.

### WARNING

UNDER TEXAS LAW (CHAPTER 87, CIVIL PRACTICE AND REMEDIES CODE), A LIVESTOCK SHOW SPONSOR IS NOT LIABLE FOR AN INJURY TO OR THE DEATH OF A PARTICIPANT IN A LIVESTOCK SHOW RESULTING FROM THE INHERENT RISKS OF LIVESTOCK SHOW ACTIVITIES.

<https://statutes.capitol.texas.gov/Docs/CP/htm/CP.87.htm#87>

Produced by Extension Horse Specialists, Texas A&M AgriLife Extension Service, Department of Animal Science.

Official Publication # AS 3-2.043  
(Revised Internally )

Texas A&M AgriLife Extension Service is an equal opportunity employer and program provider.

Texas A&M AgriLife Extension Service provides equal opportunities in its programs and employment to all persons, regardless of race, color, sex, religion, national origin, disability, age, genetic information, veteran status, sexual orientation, or gender identity. The Texas A&M University System, U.S. Department of Agriculture, and the County Commissioners Courts of Texas Cooperating.